



ITEM# 63033

4-Burner LP Gas Grill

WARNING

Improper installation, adjustment, alteration, service or maintenance can cause injury or Read the installation, operations and maintenance instructions thoroughly before installing or servicing this equipment.

DANGER

Failure to follow these instructions could result in a fire or explosion that could cause property damage, personal injury or death.

DANGER

DO NOT use gas grill for indoor cooking or heating. TOXIC fumes can accumulate and cause asphyxiation. DO NOT use in or on boats or recreational vehicles.

PROP 65 WARNING

Chemicals known to the state of to cause cancer, birth defects or other reproductive are created by the combustion of propane.



WARNING
FOR YOUR SAFETY:

For Outdoor Use Only
(outside any enclosure)



SAVE THESE INSTRUCTIONS FOR FUTURE REFERENCE. IF YOU ARE ASSEMBLING THIS UNIT FOR SOMEONE ELSE, GIVE THIS MANUAL TO HIM OR HER TO SAVE FOR FUTURE REFERENCE. FOR CUSTOMER SERVICE, EMAIL TO SERVICE@BBQTEK.COM OR CALL 1-888-571-6888 (TOLL-FREE), 6 A.M. – 5 P.M. (PST), MONDAY-FRIDAY.



Grill Operation 1-2-3

Before Grilling.

- Step 1 Keep your grill a safe distance away from your property.*
- Step 2 Always Perform a Leak Test. *
- Step 3 Keep children away from the grill.

During Grilling.

(To avoid tripping safety valves, please follow these instructions carefully!)

- Step 1 First open lid and turn gas tank on slowly.
- Step 2 Turn only one knob on at a time when lighting up the grill.
- Step 3 Use protective gloves when grill gets hot.

After Grilling.

- Step 1 Burn grill for 10-15 minutes to burn off food residues.
- Step 2 Wait until the grill is completely cooled before closing lid.
- Step 3 Clean up grease build-up and cover your grill.

* Please refer to the owner's manual for details.



WARNING

1. DO not store or use gasoline or other flammable liquids or vapor in the vicinity of this or any other appliance.
2. A LP cylinder not connected for use shall not be stored in the vicinity of this or any other appliance.



DANGER

If you smell gas:

1. Shut off gas to the appliance.
2. Extinguish any open flame.
3. Open lid.
4. If odor continues, keep away from the appliance and immediately call your gas supplier or your fire department.

Always read and understand the WARNINGS and INSTRUCTION that are contained in this manual before attempting to use this gas barbecue grill, to prevent possible bodily injury or property damage.

Always keep this manual for convenient future reference.

Table of Contents

| | |
|--|-----------|
| For Your Safety..... | 3 |
| Illustrated Parts List | 5 |
| Hardware List..... | 6 |
| Assembly Instructions..... | 7 |
| Operating Your Grill..... | 16 |
| Connecting Gas Cylinder..... | 17 |
| Checking for Leaks..... | 17 |
| Lighting Your Grill..... | 17 |
| Excess flow safety valve reset procedure..... | 19 |
| Care and Maintenance..... | 20 |
| Award-Winning Barbecue Recipes..... | 22 |
| Troubleshooting..... | 23 |
| Warranty Program..... | 25 |

For Your Safety

Dear Valued Customer,

Congratulations on your new barbecue grill purchase! You've made the right choice. In this manual, you will find assembly instructions, suggestions for grilling and helpful hints, as well as guidelines for the safe operations, proper care and use of your grill. Our expert staff strives to provide you with an easy to assemble product. Should you have any questions or problems with this product, please call our customer service department at 1-888-571-6888
6:00 am - 5:00 pm (PST), Monday through Friday.

NOTE: The use and installation of this product must conform to local codes. In the absence of local codes, use the National Fuel Gas Code, ANSI Z223.1/ NFPA54. Reference to Natural Gas and Propane Installation Code CSA B149.1 or Propane Storage and Handling code B149.2

IMPORTANT NOTICE: READ ALL INSTRUCTIONS PRIOR TO ASSEMBLY AND USE

Safety First!

Read and understand all warnings and precautions prior to operating your grill.

WARNING

1. This grill is for outside use only. It should not be used in a building, garage or any other enclosed area.
2. The use of alcohol, prescription or non-prescription drugs may impair an individual's ability to properly assemble or safely operate this appliance.
3. Always open the grill lid carefully and slowly as heat and steam trapped within the grill could cause severe burns.
4. Always place your grill on a hard and level surface far away from combustible materials and structures. An asphalt or blacktop surface may not be acceptable for this purpose.
5. Do not leave a lit grill unattended.
6. Keep children and pets away from the grill at all times.
7. This is not a tabletop grill. Do not place this grill on any type of tabletop surface.
8. Do not use the grill in high winds.
9. This grill must be used with propane gas only (propane gas cylinder not included)
10. Do not attempt to attach this grill to the self-contained propane system of a camper, trailer, motor home or house.
11. Do not use charcoal or lighter fluid.
12. Do not use gasoline, kerosene or alcohol for lighting. The LP-gas supply cylinder must be constructed and marked in accordance with the specifications for propane gas cylinders of the U.S. Department of Transportation (DOT) CFR 49.
13. This outdoor gas appliance is not intended to be installed in or on recreation vehicles and/or boats.
14. Do not attempt to move the grill while it is lit.
15. Do not use the grill unless it is **COMPLETELY** assembled and all parts are securely fastened and tightened.
16. Keep combustible items and surfaces at least 24 inches away from the grill at all times. DO NOT use this gas grill or any gas product under any overhead enclosure or near any unprotected combustible constructions.
17. Do not use in an explosive atmosphere. Keep grill area clear and free from combustible materials, gasoline and other flammable vapors and liquids.
18. Do not attempt to use or assemble with missing or damaged parts. Contact customer service for a replacement.

CAUTION-Prevention of Burns

1. To avoid burns, do not touch metal parts of the grill until they have completely cooled for at least 45 minutes or unless you are wearing protective gear such as pot holders, protective gloves or mittens.
2. Do not alter the grill in any manner.
3. Clean and inspect the hose before each use. If there is evidence of abrasion, wear, cuts or leaks, the hose must be replaced prior to operation. The replacement hose assembly should be in accordance with the manufacturer's specifications.
4. Move gas hoses as far away as possible from hot surfaces and dripping hot grease.
5. Never keep a filled gas container in a hot car or car trunk. Heat will cause the gas pressure to increase, which could open the relief valve and allow gas to escape.

Safe Locations For Use Of This Outdoor Grill

DANGER

Never use this outdoor grill inside any building, garage, shed or breezeway, or inside any boat, trailer or recreational vehicle, to prevent a possible fire and to prevent the possibility of carbon monoxide poisoning or asphyxiation.

WARNINGS

Do not use this appliance under overhead combustible surface or covered area (e.g., awnings, umbrellas, porches or gazeboes).

Always confirm that this grill is not positioned under the overhang of a house, a garage or other structure before lighting it. An overhang will serve to deflect flare-ups and radiated heat into the structure itself, which could result in a fire.

Always confirm that this grill is positioned more than 24 inches (61 cm) away from any combustible materials or surface before lighting it, and that no gasoline or other volatile substances are stored in the vicinity of this grill. (See diagram to right). The temperature of a grease fire or of the radiated heat might otherwise be sufficient to ignite nearby combustible or volatile substances.

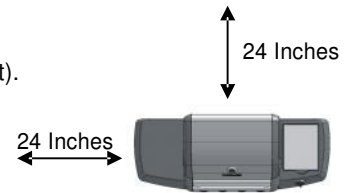

Always locate this grill where there will be ample combustion and ventilation air, but never position it in the direct path of a strong wind.

Never allow the grill to operate while unattended, to prevent uncontrolled grease fires from erupting.

Never attempt to move this grill while it is in operation or while it is still hot, to prevent possible personal injury. Never store or use gasoline or other flammable or volatile substances in the vicinity of this grill or in the vicinity of any other heating-generating appliance, because of the danger of starting a fire.

Always confirm that the installation of this grill conforms with the requirements of all local codes or, in the absence of applicable local codes, with either the National Fuel Gas Code, ANSI Z223. NFPA 54 or CAN/CGA-B149.2.



Liquid propane (LP) gas is flammable and hazardous if handled improperly. Become aware of its characteristics before using any propane product.

- Propane Characteristics: Flammable, explosive under pressure, heavier than air and settles in pools in low area.
- In its natural state, propane has no odor. For your safety, an odorant has been added.
- Contact with propane could cause freeze burns to the skin.
- This grill is shipped from the factory for propane gas use only.
- Never use a propane cylinder with a damaged body, valve, collar or footing.
- Dented or rusted propane cylinders may be hazardous and should be checked by your propane gas supplier.

CAUTION

- It is essential to keep the grill's valve compartment, burners and circulating air passages clean.
- Inspect the grill before each use.

Step 1. Inspect all hoses and connections and make certain they are secure.

Step 2. Check and clean the burner venturi tubes for insects and insect nests by removing the burner and inserting a bottle brush cleaner into each tube to make sure the passage is clear.

*** A clogged tube can lead to a fire beneath the grill. ***

Step 3. Ensure that the valve nozzle is pointing straight and completely inserted into the venturitube.

GENERAL INFORMATION



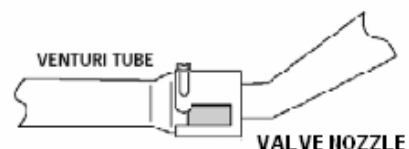





1. A propane gas cylinder is required for operation.
2. This gas grill is NOT intended for commercial use.



Illustrated Parts List

| | | | |
|---|---|--|---|
| <p>1. Left side panel.....1pc</p>  | <p>2. Right side panel1pc</p>  | <p>3. Bottom panel assembly...1pc</p>  | <p>4. Back panel..... 1pc</p>  |
| <p>5. Front top beam..... 1pc</p>  | <p>6. Main doors.....2pcs</p>  | <p>7. Heat insulation plate.....1pc</p>  | <p>8. Grill body assembly.....1pc</p>  |
| <p>9. Left side shelf.....1pc</p>  | <p>10. Right side shelf1pc</p>  | <p>11. Side burner assembly....1pc</p>  | <p>12. Heat plate.....4pcs</p>  |
| <p>13. Cooking grate.....2pcs</p>  | <p>14. Warming grate-body.....1pc</p>  | <p>15. Warming grate-lid.....1pc</p>  | <p>16. Cup seat.....1pc</p>  |
| <p>17. Grease cup.....1pc</p>  | <p>18. Tank clip..... 1pc</p>  | <p>19. Storage basket.....1pc</p>  | <p>20. Side burner knob.....1pc</p>  |
| <p>21.Side knob seat.....1pc</p>  | | | |

Hardware List

| | | | | | | | |
|---|---|---------------|-------|---|--|--------------|------|
| A |  | M6x15mm Bolt | 6pcs | F |  | M4x12mm Bolt | 6pcs |
| B |  | M6x20mm Bolt | 4pcs | G |  | Small Washer | 6pcs |
| C |  | M6x45mm Bolt | 4pcs | H |  | M4 Nut | 4pcs |
| D |  | Spring Washer | 10pcs | I |  | Screwdriver | 1pc |
| E |  | Large Washer | 14pcs | | | | |

**Hardware listed above is not scaled to exact size.
(A screwdriver is required on assembly and is included for your convenience).**

Assembly Instructions

Remove all contents from the carton packaging. Make sure all parts are present before attempting assembly. Once the grill is fully assembled, go back and check to make certain all the bolts are tightened. Tighten again using the screwdriver provided if necessary.

Estimated Assembly Time: 50 minutes.

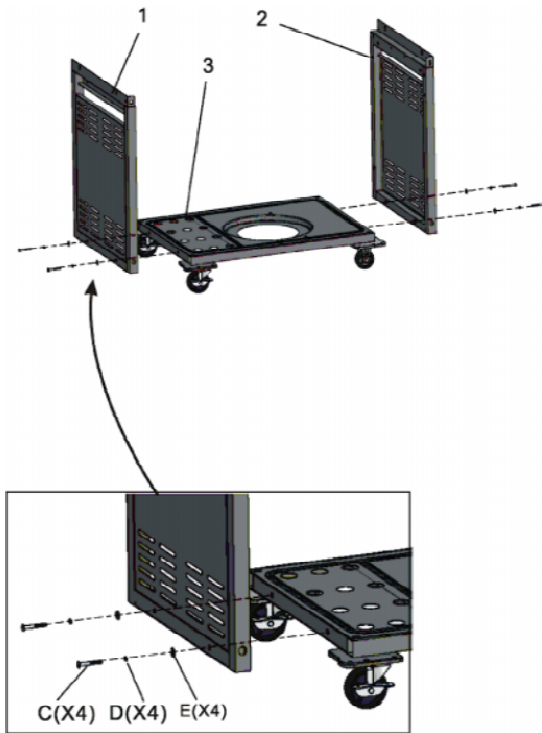

Step 1

Note: Before beginning assembly, make certain the two swivel casters on the bottom panel assembly are locked.

- Align the holes on the bottom of the left side panel (1) with the holes on the left side of the bottom panel assembly (3).
- Insert one M6x45mm bolt (C), one spring washer (D) and one M6 washer (E) into each pre-drilled hole.
- Tighten by hand until secure.
- Repeat the procedure for the right side panel (2).
- Go back to tighten all the bolts using the screwdriver provided.

Step 2

- Loosen four back panel bolts (pre-attached).
- Insert the back panel (4) and push down until the back panel locks into place.
- Tighten by hand until secure.
- Go back to tighten all the bolts using the screwdriver provided.

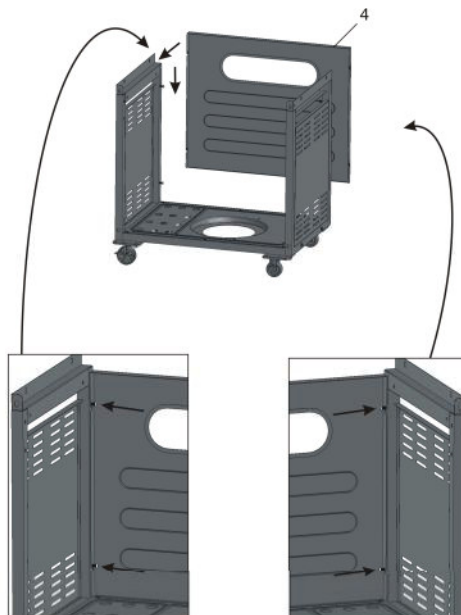

Step 3

- Place the front top beam (5) on front of the cart assembly.
- Align the holes on the left inside of the cart assembly with holes on the front top beam.
- Insert one M6x20mm Bolt (A), one spring washer (D) and one M4 washer (E) into each hole. Tighten by hand until secure.
- Repeat the procedure for right inside of the cart assembly.
- Go back to tighten all the bolts using the screwdriver provided.

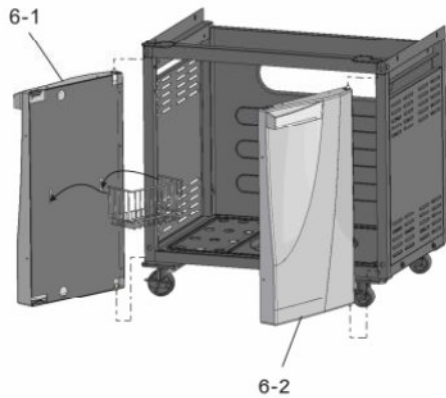
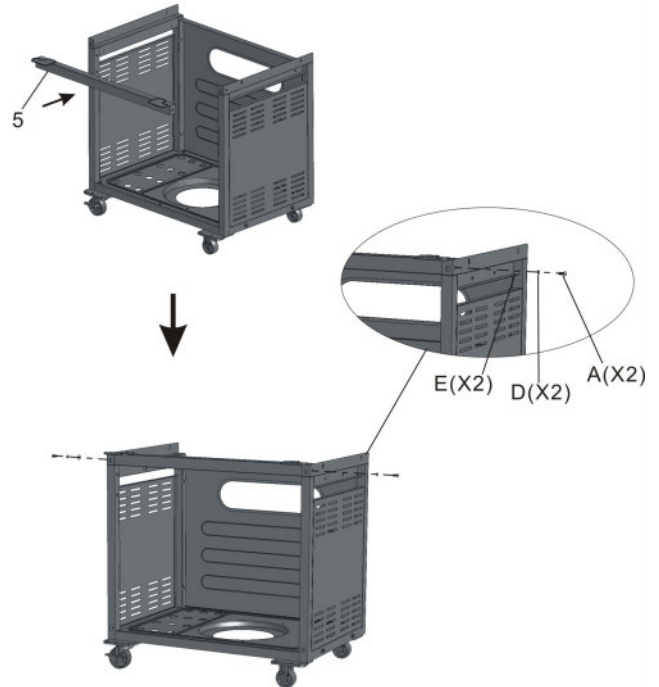

Step 4

- Slide the storage basket (18) onto the slots on the right door (6-1).
- Insert the pin on the bottom of the left door (6-1) into the hole on the left bottom side of the cart assembly.
- Push down the pin on top of the left door (6-1) and insert into the hole on the left side of the cart front beam.
- Repeat the same procedure for the right door (6-2).

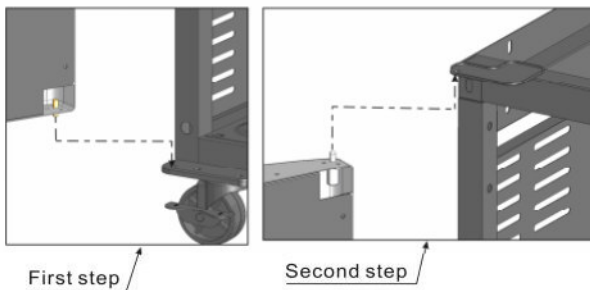

Step 5

- Slide the heat insulation plate (7) into the back of the cart assembly.
- Align the hole on the cart with pre-drilled holes on heat insulation plate.
- Screw one M6 bolt (A) and one M4 washer (E) into each pre-drilled hole.
- Tighten all the bolts using the screwdriver provided.

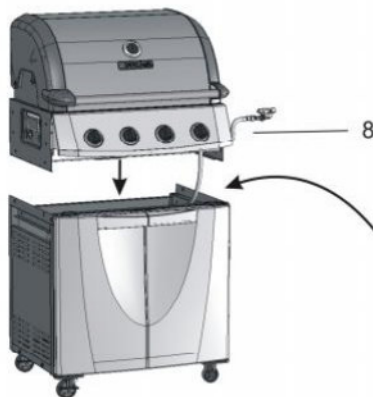
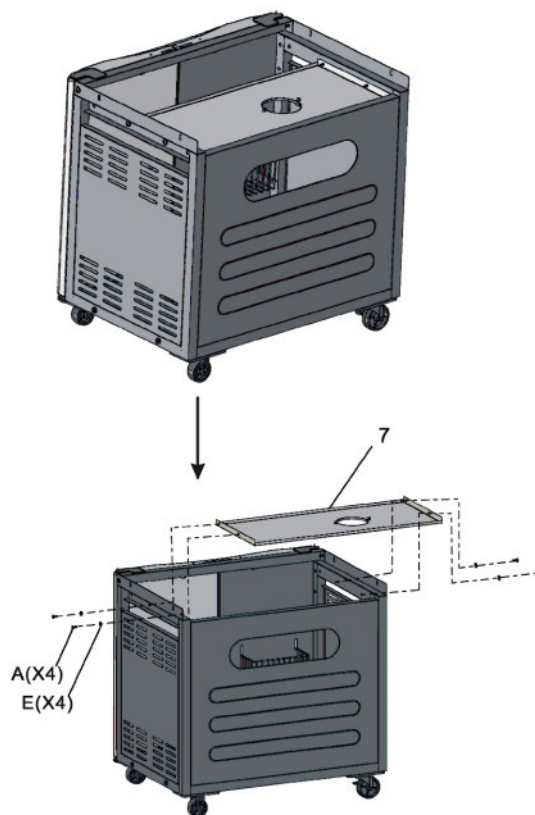

Step 6

- Place the body assembly (8) on top of the cart assembly.
Note: Make certain the pre-drilled holes on the right side of the body assembly are properly aligned.
- Insert one M4 bolt (B), one spring washer (D) and one M4 washer (E) into each hole on right side of the body assembly.
- Tighten the bolt by hand until secured.
- Repeat the procedure for the left side of the body assembly.
- Go back to tighten all the bolts using the screwdriver provided.

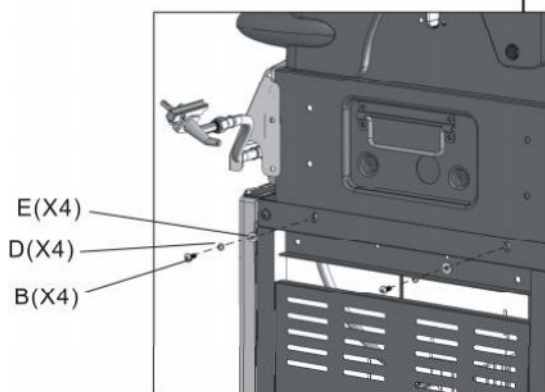

Step 7

- a) Loosen the four side panel bolts (pre-attached) on the left side of the body assembly and allow 1/4 of the bolts length to extend from the body assembly.
- b) Align the large holes of the left side shelf (9) with the bolts extended from the body assembly.
- c) Push down the left side shelf until the shelf locks into place.
- d) Tighten bolt by hand until secure.
- e) Repeat the same procedure for the right side shelf (10).
- f) Go back to tighten all the bolts using the screwdriver provided.

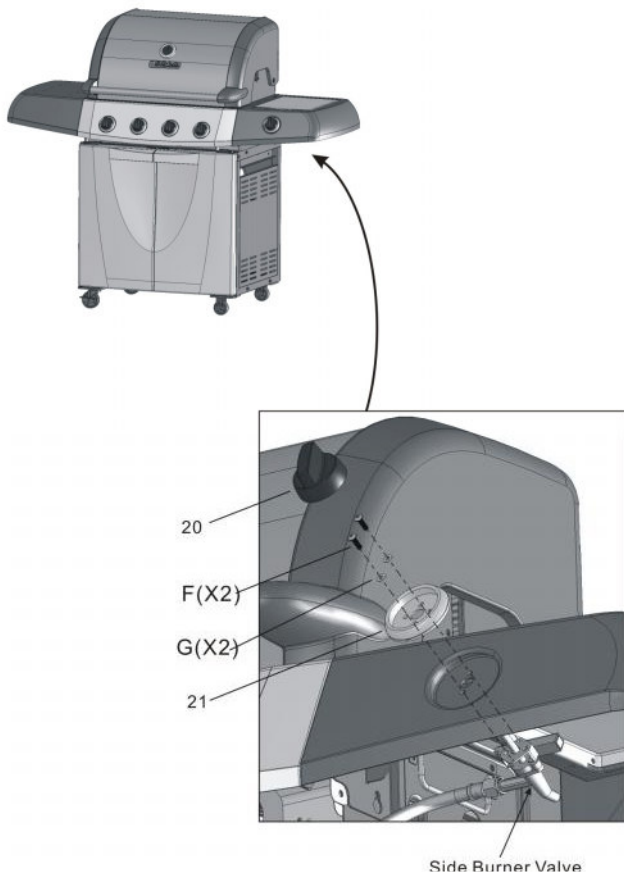
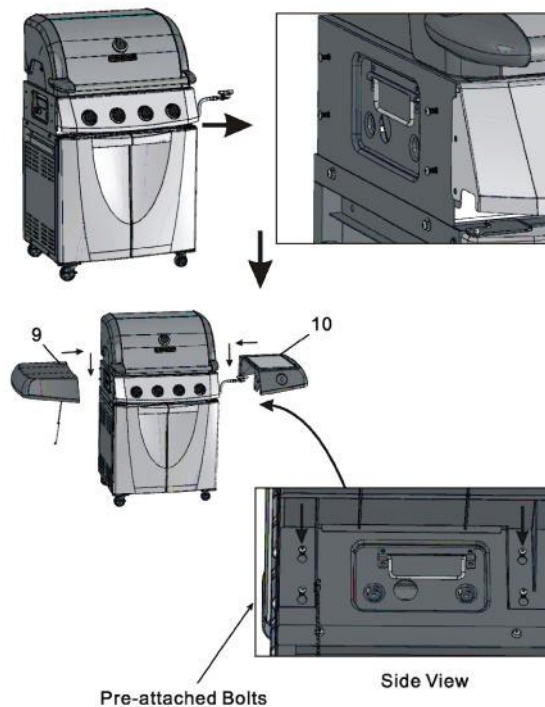

Step 8

- a) Align the holes on side knob seat (21) with the holes on the right side shelf and side burner valve.
- b) Screw one M4x16mm bolt (F) and one small washer (G) into each pre-drilled hole.
- c) Tighten the bolts with the screwdriver provided.
- d) Insert the side burner knob (20) into knob shaft of valve.

Step 9

- a) Open the side burner lid and place the side burner assembly (11) on the right side shelf. Make certain the venturi tube is connected properly with valve.
- b) Align the holes on the side burner assembly with the holes on the right side shelf (10).
- c) Insert one M4 bolts (F) into each hole on side burner assembly and insert a small washer (G) and one M4 nut (H) from bottom side into each bolt and tighten by hand.
- d) Go back to tighten all the bolts using screwdriver provided.

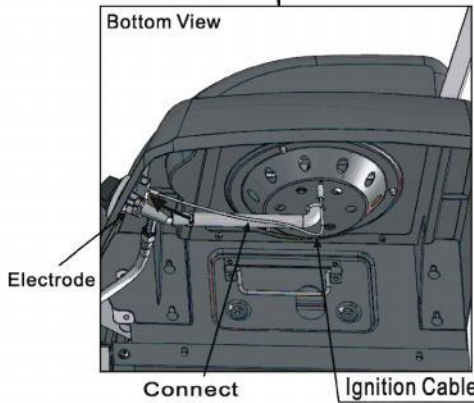
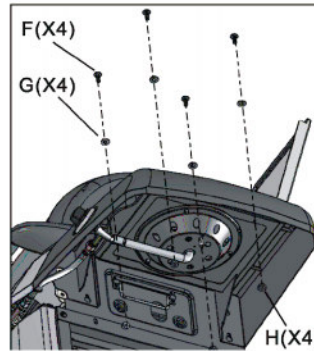
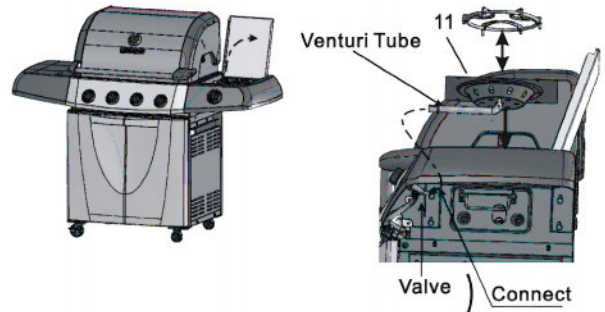

Step 10

- a) Connect the ignition cable with the electrode by insert the connector of the ignition cable to electrode pin.
- b) Make certain the connection is secured.

Step 1

- a) Place the four heat plates (12) inside the grill upon the burners.
- b) Place the two cooking grates (13) inside the grill upon the heat plates.
- c) Insert the four feet of the warming grate-body (14) into the holes on top of grill body.
- d) Insert two ends of side warming grate-lid (15) into the holes on inside of the top lid.

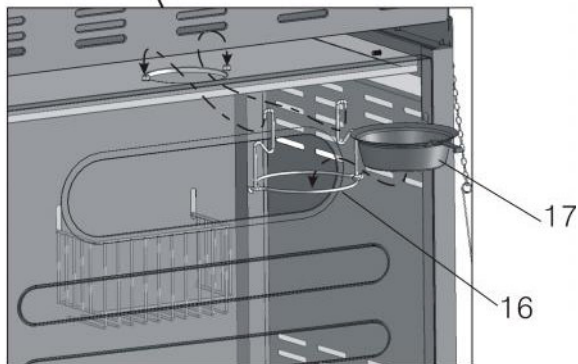
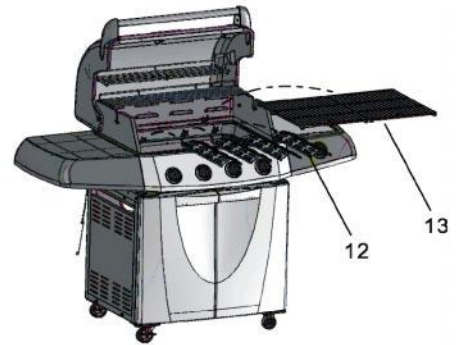
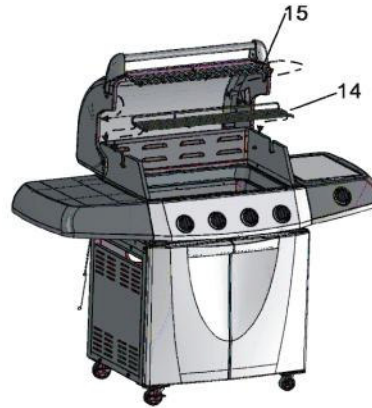

Step 12

- a) Hook the cup seat (16) into the grooves under the heat insulation plate.
- b) Place the grease cup (17) on the cup support.

Step 13

- a) Insert the tank clip (18) into the holes on the gas tank support.
- b) Place the gas tank on the tank seat and clip it by the tank clip (18).
- c) Connect the tank with regulator by screw the collar onto the tank valve. (See diagram to right).
- d) Make certain all connections are connected securely.
- f) Perform a leak test as page 15.

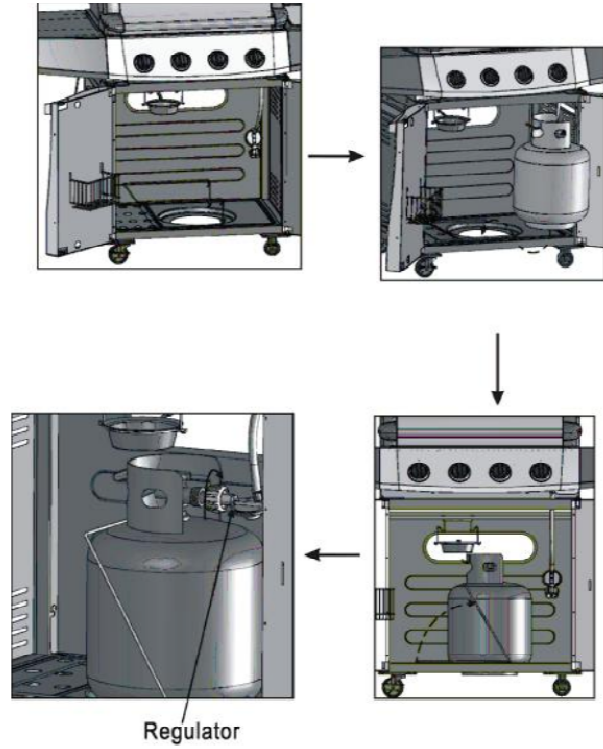

Fully Assembled View



Operating Your Grill

CAUTION:

Use only the regulator provided. If a replacement is necessary, call our customer service center. The use of unauthorized parts can create an unsafe condition and environment.

The propane gas supply cylinder used must be constructed and marked in accordance with the *Specifications for Propane Gas Cylinders* of the U.S. Department of Transportation (DOT). Only cylinders with a listed overfill prevention device (OPD) and marked "propane" may be used. Cylinders with an OPD will have valve handles with three "lobes" (prongs).

The pressure regulator and hose assembly supplied with the outdoor cooking gas appliance must be used. Replacement pressure regulators and hose assembly must be those specified by the outdoor cooking gas appliance manufacturer. Only use 20 pound cylinders equipped with a cylinder connection device compatible with the connection for outdoor cooking appliances. The cylinder must include a collar to protect the cylinder valve. The gas cylinder should not be dropped or handled roughly. If the appliance is not in use, the gas cylinder must be disconnected.

Storage of the appliance indoors is permissible ONLY if the cylinder is disconnected and removed from the appliance. Cylinders must be stored outdoors and out of the reach of children. Cylinder must not be stored in a building, garage or other enclosed area. Your cylinder must never be stored where temperatures can reach over 125F.

Before connecting, make sure there is no debris caught in the head of the gas cylinder, regulator valve or in the head of the burner and burner ports. Connect regulator valve and hand tighten firmly. Disconnect the propane cylinder from the regulator valve when the grill is not in use. DO NOT obstruct the flow of combustion air or ventilation air to the grill. The propane cylinder must be arranged for vapor withdrawal and equipped with a listed overfill prevention device (OPD).

Danger: A fire causing death or serious injury may occur if the following is not followed exactly:

Never store or use gasoline or other volatile substances in the vicinity of this grill.

Never store a spare propane cylinder under or in the vicinity of this grill, or in the vicinity of another potential heat source.

Never fill the propane cylinder beyond 80% full.



Warning: Don't store spare gas cylinder in or near grill.

Connecting the Gas Cylinder

LP (Propane) Gas Supply Connection

1. Always place the propane cylinder on the tank brackets located on the right side of the cart.
2. Always confirm that all burner control knobs are in the OFF position before activating the gas supply.
3. Before connection, be sure that there is no debris caught in the head of the gas cylinder, head of the regulator valve, or in the head of the burner and burner ports.
4. Always connect the gas supply regulators as follows:
Insert the nipple of the valve coupling into the tank valve and tighten the connection collar by turning it clockwise with one hand while holding the regulator with the other hand.
(See diagram to right)
5. Disconnect the propane cylinder from the regulator valve when the grill is not in use.
6. Do not obstruct the flow of combustion air and ventilation air to the grill.
7. Keep ventilation openings of the cylinder enclosure free and clear from debris.
8. Place dust cap on cylinder valve outlet whenever the cylinder is not in use. Only install the type of dust cap on cylinder valve outlet that is provided with the cylinder valve. Other types of caps or plugs may result in leakage of propane.



DANGER

To prevent fire or explosion hazard when testing for a leak:

1. Always perform the "leak test" on page 15 before lighting the grill and each time the cylinder is connected for use.
2. Do not smoke or allow other sources of ignition in the area while conducting a leak test.

3. Conduct the leak test outdoors in a well-ventilated area.
4. Do not use matches, lighters or a flame to check for leaks.
5. Do not use grill until all leaks have been stopped. If you are unable to stop a leak, disconnect the propane supply, call for gas appliance service or your local propane gas supplier.

Checking for Leaks

1. Make 2-3 oz. of leak solution by mixing one part liquid dishwashing soap with three parts water.
2. Make sure control knobs are in the "OFF" position.
3. Spray some solution on the tank valve up to the regulator connection.
(See diagram to right).
4. Inspect the solution at the connections for bubbles. If no bubbles appear, the connection is secure.
5. If bubbles appear, you have a leak. Go to step 6.
6. Disconnect the regulator from the tank and reconnect. Make sure the connection is secure.
7. Retest with solution.
8. If you continue to see bubbles, replace the cylinder.



Lighting Your Grill

! Danger: Failure to open lid while igniting the grill's burners or not waiting 5 minutes to allow gas to clear if the grill does not light, may result in an explosion, which could cause serious bodily injury or death.

! WARNING: Never stand with your head directly over the grill when preparing to light the main burners, to prevent possible bodily injury.

Main Burner

1. Open lid while lighting burners.
 - ! WARNING:** Attempting to light the burner with the lid closed may cause an explosion. Make sure there are no obstructions of airflow to the gas unit. Spiders and insects can nest and clog the burner / venturi tube at the orifice. A clogged burner tube can lead to a fire beneath the appliance.
2. All valves must be in the "OFF" position.
3. Open cylinder valve.
4. Ignite only the burners you wish to use, using the asme method for each:
Push desired burner valve knob and rotate slowly about 1/4 counter-clockwise until a click is heard. The burner should light. If the burner does not light, return the valve knob to the "OFF" position immediately. Wait five minutes for the gas to clear and repeat the procedure. After burner is lit, repeat the procedure with any other burner desired.
5. Adjust valve knob(s) to desired cooking temperature.

Using the Lighting Stick to Light the Main Burners

1. Insert a match into the end of lighting stick. Light the match.
2. Once lit, place the flame through the hole on grill body to reach the burner ports.
(See diagram to right).
3. Press the valve knob and rotate it counter clockwise to the "HIGH" position. The burner should light immediately. If more than one burner is desired, repeat the same procedure for the adjacent burner and continue in sequence until all desired burners are lit.
4. Adjust burners to the desired cooking temperature.

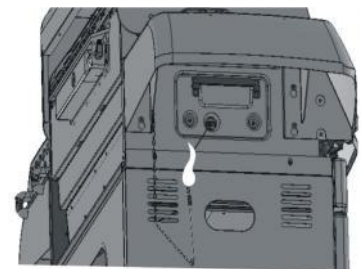

! Precautions

1. After lighting, observe the burner flame. Make sure all burner ports are lit.
2. If the burner flame goes out during operation, immediately turn the gas "OFF". Open lid to let the gas clear for at least 5 minutes before re-lighting.
3. Before cooking on the grill for the first time, operate the grill for approximately 15 minutes with the lid closed and the gas turned on "HIGH". This will "heat clean" the internal parts, dissipate odor from the manufacturing process and painted finish.
4. Clean the grill after each use. DO NOT use abrasive or flammable cleaners. This may damage parts of the grill and cause a

fire.

Side Burner

1. Open lid while lighting the burner. Lid must remain open while burner is lit.
2. Valve must be in the "OFF" position.
3. Open cylinder valve.
4. Push side burner knob fully and rotate it slowly about 1/4 turn counter-clockwise, then press the igniter promptly. The burner should light. If the burner does not light, turn the knob to the "OFF" position immediately. Wait five minutes for the gas to clear and repeat the procedure.
5. Adjust valve knob to the desired cooking temperature.

Using the Lighting Stick to Light the Side Burner

1. Open the side top lid. Lid must remain open while burner is lit.
2. Stick out the lighting stick then insert a match into the end of lighting sticks. Light the match.
3. Once lit, place the flame through the hole on grill body to reach the burner ports. (See diagram to right).
4. Press the control knob and rotate it counter clockwise to the "HIGH" position. The burner should light immediately.
5. Adjust burner to the desired cooking temperature.

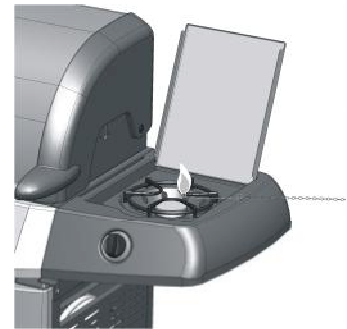

**Observe flame height when lit:
Flame should be a blue/yellow color between 1 to 2 inches high.**

Confirm that the burner is properly lit and that the flame pattern is as desired (see fig. A, B and C below for the proper flame patterns). If the flame pattern is other than normal, consult the troubleshooting guide on page 23 for corrective action.

FIG. A

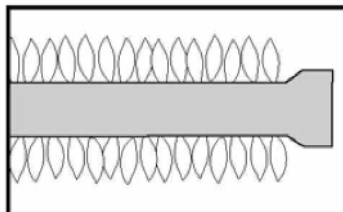

Normal: Soft blue flames with yellow tips between 1 inch - 2 inches high.

FIG. B

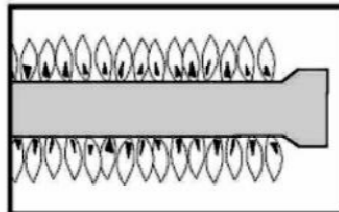

Out of adjustment: Noisy hard blue flames – too much air.

FIG. C

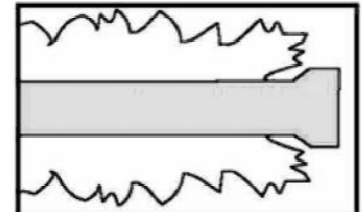

flames- too little air.

Burner installation and adjustment

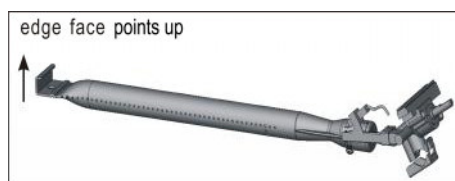

1. End edge face upside for install the burner



1. Release the screw on venturi tube.
2. Adjust the flame by turning the collar on head of venturi tube.
3. Tighten the screw and make certain it is secured.

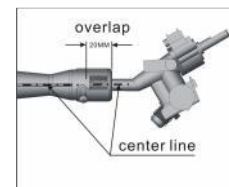

1. Overlap 20 mm between venturi tube and nozzle when assemble.
2. Keep the center line of venturi tube and nozzle on one line.

Flare-ups

“Flare-ups” sometimes occur when food drippings fall onto the hot heat distribution plate or burners and ignite. Some flaring is normal and desirable, as it helps impart the unique flavors associated with grilled foods. Controlling the intensity of the flare-ups is necessary, however, in order to avoid burned or unevenly cooked foods and to prevent the possibility of accidental fire.

! WARNING: Always monitor the grill closely when cooking and turn the flame level down to LOW or OFF, if flare-ups intensify.

Shutting Off Burners

1. Always turn the valve knob(s) clockwise to the “HIGH” position, then press and turn it to “OFF”. Never force the knob without pressing it. This could damage the valve.
2. Promptly turn the gas supply to the “OFF” position at the propane cylinder.
3. Close the lid of the grill.

Excess flow safety valve reset procedure

- The new regulators are equipped with a safety device that restricts the gas flow in the event of a gas leak. However, unsafe practices of grill operation could activate the safety device without having a gas leak.
- A sudden shut off of the gas flow typically occurs if you open the LP tank valve rapidly, or if one or more of the burner control knobs is in an open position when opening the LP tank valve.
- To ensure the procedure is safely and successfully performed, please carefully follow the instructions as:
 1. Close the LP tank valve.
 2. Turn all burner control knobs to the OFF position.
 3. Disconnect the regulator from the LP tank.
 4. Open the lid of the grill.
 5. Turn burner control knobs to HIGH.
 6. Wait at least 1 minute.
 7. Turn burner control knobs OFF.
 8. Wait for at least 5 minutes.
 9. Re-connect the regulator to the LP tank.
 10. Slowly turn the LP tank valve ¼ turn at a time and have the valve all the way open.
 11. With the lid open: For grill with ignition button: ONLY turn on ONE front burner control knob to the HIGH position. Ignite the grill by pushing the ignition button. For grill with an automatic ignition: Push down the control knob you want to light, turn counter clock wise until you hear the ignition click.
 12. After the first front burner is lit, turn on the other control knob(s) to the HIGH position. **If you have more than two burners, ONLY turn them on ONE AT A TIME.
 13. When all front burners are lit, close the grill lid.
 14. Wait for 10-15 minutes, the temperature should reach 400 – 450 F°

! WARNING: The cylinder valve always has to be above the horizontal position, for the cylinder to have vapor withdrawal only.

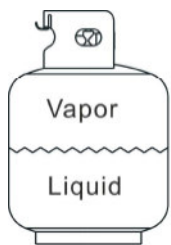

CORRECT

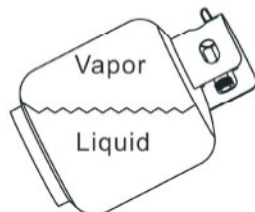

WRONG

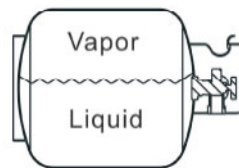

WRONG

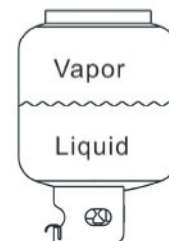

WRONG

Care and Maintenance

IMPORTANT

Always allow to completely cool off before covering your grill to prevent corrosion from condensation.

 **Caution:** All cleaning and maintenance should be done when the grill is cool, with the fuel supply turned off at the control dial and the propane cylinder disconnected. DO NOT clean any grill part in a self-cleaning oven. The extreme heat will damage the finish.

Cleaning

Burning off the grill after every use (approx. 15 minutes) will keep excessive food residue from building up.

Recommended cleaning materials -

| | |
|-----------------------------------|----------------------|
| Mild dishwashing liquid detergent | Hot water |
| Nylon cleaning pad | Wire brush |
| Paper clip | Putty knife/scrapper |
| Compressed air | |

DO NOT use cleaners that contain acid, mineral spirits or xylene.

Outside surfaces

Use a mild dishwashing detergent and hot water solution to clean. Rinse thoroughly with water.

Inside surface

If the inside surface of the grill lid has the appearance of peeling paint, baked on grease has turned to carbon and is flaking off. Clean thoroughly with a strong solution of detergent and hot water. Rinse with water and allow it to completely dry.

Interior of grill bottom – Remove residue using brush, scraper and/or cleaning pad. Wash with a dishwashing detergent and hot water solution. Rinse with water and let dry.

Cooking Grates – The porcelain grates have a glass-like composition that should be handled with care. Use a mild dishwashing detergent or baking soda and hot water solution. Non-abrasive scouring powder can be used on stubborn stains. Rinse with water.

Heat Plates – Clean residue with wire brush and wash with soapy water. Rinse with water.

Grease Cup – Periodically empty the grease cup and clean with a dishwashing detergent and hot water solution.

Cleaning the Burner Assembly

1. Turn gas off at the control knobs and propane tank.
2. Remove cooking grates and heat plate.
3. Remove grease cup.
4. Remove burner by unscrewing nut from beneath burner “foot” using a screwdriver and pliers.
5. Lift burner up and away from the gas valve orifice.
6. Clean inlet (venturi tube) of burner with small bottle brush or compressed air.
7. Remove all food residues and dirt on outside of burner surface.
8. Clean any clogged ports with a stiff wire (such as an opened paper clip).
9. Inspect burner for damage (cracks or holes). If damage is found, replace with a new burner. Reinstall burner. Make certain the gas valve orifices are correctly positioned, pointing straight into burner inlet (venturi tube). Also, check position of spark electrode.

Award-Winning Barbecue Recipes

Never-Fail Barbecue Sauce

Ingredients:

| | |
|---------------|------------------------------|
| ¼ cup | Finely chopped onion |
| 2 tablespoons | Butter or margarine |
| ¼ cup | Brown sugar, firmly packed |
| 1 tablespoon | Worcestershire sauce |
| ¼ teaspoon | Hot sauce |
| 1 | Garlic clove, finely chopped |
| 1 cup | Catsup |
| ¼ cup | Lemon juice |
| 1 tea spoon | Prepared mustard |

Prepare:

Cook onion and garlic in margarine until tender. Add remaining ingredients and bring to a boil. Simmering covered 15 to 20 minutes. Refrigerate leftovers after use.

Mamma's Marinated Chicken

Ingredients:

| | |
|---------------|--|
| ¼ cup | Dijon mustard |
| 2 tablespoons | Fresh lemon juice |
| 1 ½ teaspoons | Worcestershire sauce |
| ½ teaspoon | Dried tarragon |
| ¼ teaspoon | Freshly ground black pepper |
| 4 | Boneless, skin less chicken breast halve |

Prepare:

Combine ingredients, mixing well. Marinade chicken for several hours. Grill uncovered, over medium heat, for 10 to 15 minutes. Chicken is done when juices run clear.

Barbecued Honey Steak

Ingredients:

| | |
|---------------|--------------------------|
| 5 pounds | Beef sirloin steak |
| 2 tablespoons | Red pepper -- crushed |
| 1 teaspoon | Black pepper |
| 2 | Garlic cloves -- crushed |
| 1 | large Onion |
| 1 cup | Honey |

Prepare:

Combine all ingredients and marinate steak for 7-8 hours. Remove meat from marinade and grill over very high heat to desired doneness. Heat leftover marinade to a boil and pour over grilled steak to serve.

Hardcore Grilled Trout

Ingredients:

| | |
|---------------|-----------------------------------|
| ¼ cup | Lemon or lime juice |
| 2 tablespoons | Melted butter |
| 2 tablespoons | Vegetable oil |
| 2 tablespoons | Chopped parsley |
| 1 tablespoon | Hot sauce |
| ½ teaspoon | Ground ginger |
| ½ teaspoon | Salt |
| 4 | brook trout -- about 1 pound each |

Prepare:

Combine lemon juice, margarine, oil, parsley, hot sauce, ginger and salt. Mix well. Pierce skin of fish in several places. Roll fish in juice mixture to coat inside and out. Cover and refrigerate 30 minutes to 1 hour, turning occasionally. Remove fish from marinade. Place fish on grill; brush fish with marinade while grilling. Cook over high heat for 5 minutes. Turn and brush with marinade. Cook 5 minutes longer. Fish is done when it flakes easily with fork.

Grilled Veggies

Ingredients:

| | |
|--------------|---|
| ¾ cup | Olive oil |
| ¼ cup | Red wine vinegar |
| 1 teaspoon | Fresh rosemary |
| 1 teaspoon | Fresh thyme leaves |
| 1 teaspoon | Fresh basil, chopped |
| 1 teaspoon | Fresh oregano, chopped |
| 1 tablespoon | Minced garlic |
| ½ teaspoon | Salt |
| ½ teaspoon | Ground black pepper |
| 2 pounds | assorted vegetables, chopped or whole according to taste. |

Prepare

Combine all ingredients in a small bowl. Marinade vegetables with sauce. Cover and refrigerate for 2 hrs. Grill vegetables over medium heat until tender, brushing them with marinade while they cook. Cooking times will vary according to the vegetables chosen.

Troubleshooting

| Problem | Possible Cause | Prevention/Cure |
|--|---|--|
| Burner will not light using knobs or igniter. | Wires/or electrode covered with cooking residue. | Clean wire and /or electrode with rubbing alcohol. |
| | Electrode and burners are wet. | Wipe dry with cloth. |
| | Electrode cracked or broken – sparks at crack. | Replace electrode. |
| | Wire loose or disconnected. | Reconnect wire or replace electrode/wire assembly. |
| Burner will not light using a match. | No gas flow. | Check if propane tank is empty. If empty, replace or refill. If propane tank is not empty, refer to Excessive flow safety valve reset procedure on page 17. |
| | Coupling nut and regulator not fully connected. | Turn the coupling nut about one-half to three quarters additional turn until so lid stop. Tighten by hand and ONLY - do not use tools. |
| | Obstruction of gas flow. | Clear burner tubes. Check for bent or kinked hose. |
| | Disengagement of burner to valve. | Reengage burner and valve. |
| | Spider webs or insect nest in venturi. | Clean venturi. |
| | Burner ports clogged or blocked. | Clean burner ports. |
| Sudden drop in gas flow or reduced flame height. | Tank out of gas. | Check for gas in propane tank. |
| | Excess safety device may have been activated. | Refer to the Excessive flow safety valve reset procedure on page 17. |
| Irregular flame pattern, flame does not run the full length of burner. | Burner ports are clogged or blocked. | Clean burner ports. |
| Flame is yellow or orange. | New burner may have residual manufacturing oils. | Burn grill for 15 minutes with the lid closed. |
| | Spider webs or insect nest in venturi. | Clean venturi. |
| | Food residue, grease or seasoning salt on burner. | Clean burner. |
| | Poor alignment of valve to burner venturi. | Assure burner venturi is properly engaged with valve. |

| | | |
|---|--|---|
| Flame blew out. | High or gusting winds. | Turn front of grill to face wind or increase flame height. |
| | Low on propane gas. | Replace or refill propane tank. |
| | Excess flow valve tripped. | Refer to the Excessive flow safety valve reset procedure on page 17. |
| Flare-up. | Grease buildup. | Clean grill. |
| | Excessive fat in meat. | Trim fat from meat before grilling. |
| | Excessive cooking temperature. | Adjust (lower) temperature accordingly. |
| Persistent grease fire. | Grease trapped by food buildup around burner system. | Turn knobs to OFF. Turn gas OFF at propane tank. Leave lid in closed position and let fire burn out. After grill cools, remove and clean all parts. |
| Flashback [fire in burner tubes] | Burner and /or burner tubes are locked. | Clean burner and/or burner tube(s). |
| Inside of lid is peeling – like pant peeling. | The lid is stainless steel, not painted. | Baked on grease buildup has turned to carbon and is flaking off. Clean thoroughly. |
| Irregular flame. | Air flow is not correct. <u>Correct</u> Flame blue with yellow tips, 1-2" high. <u>Too little air</u> : wavy yellow or orange flames. <u>Too much air</u> : noisy blue flames. | If flames are yellow or orange – open flap at the end of the venturi tubes in 1/8" increments until flames are correct. If flames are blue and noisy – close flap at the end of the venturi tubes in 1/8" increments until flames are correct. *Propane Model must be open a minimum of 1/8" *Natural Gas Models must be open a minimum of 1/16" |

Warranty Program

Proof of purchase is required to access this warranty program, which is in effect from the date of purchase. Inability to provide proof of purchase or after the warranty has expired, customers will be subject to parts, shipping and handling fees.

Full 30-Day Warranty

Any missing parts can be replaced at no charge within 30 days from the date of purchase, with a valid proof of purchase.

Limited Warranty

1 Year Warranty on all parts in regards to damage affecting the operation of the gas grill.

Warranty Provisions:

- This warranty is non-transferable and does not cover failures due to misuse or improper installation or maintenance.
- This warranty is for replacement of defective parts only. We are not responsible for incidental or consequential damages or labor costs.
- This warranty does not cover chips and scratches of porcelain or painted surfaces, nor does it cover corrosion or discoloration due to misuse, lack of maintenance, hostile environment, accidents, alterations, abuse or neglect.
- This warranty does not cover damage caused by heat, abrasive and chemical cleaners, resulting in chipped porcelain enamel parts or any damage to other components used in the installation or operations of the gas grill.

Inability to provide proof of purchase or after the warranty has expired, customers will be subject to parts, shipping and handling fees.

Some states do not allow the limitation or exclusion of incidental or consequential damages, so the above limitations or exclusions may not apply to you. This warranty gives you specific legal rights, and you may also have other rights that vary from state to state.

If you have any questions related to the product or warranty, please visit our website at www.bbqtek.com or email us at service@bbqtek.com or call our customer service center at 1-888-571-6888, 6:00 A.M. to 5:00 P.M. (PST), Monday through Friday.

Distributed by:

L G Sourcing Inc.
P.O. Box 1535
North Wilkesboro
NC 28659, USA