

# ULTIMATE S E R I E S

 **PERFECT FLAME®**



## **WARNING**

Improper installation, adjustment, alteration, service or maintenance can cause injury or property damage.

Read the installation, operation and maintenance instructions thoroughly before installing or servicing this equipment.

## **DANGER**

Failure to follow these instructions could result in fire or explosion that could cause property damage, personal injury or death.

## **DANGER**

DO NOT use gas grill for indoor cooking or heating. TOXIC fumes can accumulate and cause asphyxiation. DO NOT use in or on boats or recreational vehicles.

## **PROP 65 WARNING**

Chemicals known to the state of California to cause cancer, birth defects or other reproductive harm are created by the combustion of propane.



**WARNING**  
**FOR YOUR SAFETY:**

**For Outdoor Use Only**  
**(Outside any enclosure)**

## 4-Burner LP Gas Grill



**PF30LP**

**SAVE THESE INSTRUCTIONS FOR FUTURE REFERENCE. IF YOU ARE ASSEMBLING THIS UNIT FOR SOMEONE ELSE, GIVE THIS MANUAL TO HIM OR HER TO SAVE FOR FUTURE REFERENCE. FOR CUSTOMER SERVICE, EMAIL TO [SALESHELP@SUREHEAT.COM](mailto:SALESHELP@SUREHEAT.COM) OR CALL 1-800-229-5647 (TOLL-FREE) BETWEEN 8:00 AM AND 5:00 PM EASTERN TIME, MONDAY THROUGH FRIDAY**

# Grill Operation 1-2-3

## Before Grilling.

- Step 1 Keep your grill a safe distance away from your property.\*
- Step 2 Always Perform a Leak Test.\*
- Step 3 Keep children away from the grill.

## During Grilling.

(To avoid tripping safety valves, please follow these instructions carefully!)

- Step 1 First open lid and turn gas tank on slowly.
- Step 2 Turn only one knob on at a time when lighting the grill.
- Step 3 Use protective gloves when grill gets hot.

## After Grilling.

- Step 1 Burn grill for 10-15 minutes to burn off food residues.
- Step 2 Wait until the grill is completely cooled before closing lid.
- Step 3 Clean up grease build-up and cover your grill.

\* Please refer to the owner's manual for details.

### **WARNING**

1. Do not store or use gasoline or other flammable liquids or vapors in the vicinity of this or any other appliance.
2. An LP cylinder not connected for use shall not be stored in the vicinity of this or any other appliance.

### **DANGER**

If you smell gas:

1. Shut off gas to the appliance
2. Extinguish any open flame
3. Open lid
4. If odor continues, keep away from the appliance and immediately call your gas supplier or your fire department.

Always read and understand the WARNINGS and INSTRUCTION that are contained in this manual before attempting to use this gas barbecue grill, to prevent possible bodily injury or property damage.

**Always keep this manual for convenient future reference.**

# Table of Contents

<b>For Your Safety.....</b>	<b>4</b>
<b>Grill Features.....</b>	<b>6</b>
<b>Getting Started.....</b>	<b>7</b>
<b>Grill Assembly.....</b>	<b>8</b>
<b>Grill Location.....</b>	<b>12</b>
<b>Gas Requirements.....</b>	<b>13</b>
<b>Pre Operation Leak Testing.....</b>	<b>15</b>
<b>Lighting the Grill.....</b>	<b>16</b>
<b>Using the Rotisserie Burner.....</b>	<b>17</b>
<b>Rotisserie Lighting.....</b>	<b>18</b>
<b>Grill Light Maintenance.....</b>	<b>19</b>
<b>Care and Maintenance.....</b>	<b>20</b>
<b>Troubleshooting Guide.....</b>	<b>22</b>
<b>Warranty Information.....</b>	<b>24</b>

# For Your Safety

Congratulations on your new barbecue grill purchase! You've made the right choice. In this manual, you will find assembly instructions, suggestions for grilling and helpful hints, as well as guidelines for the safe operations, proper care and use of your grill. Our expert staff strives to provide you with an easy to assemble product. Should you have any questions or problems with this product, please call our customer service department at **1-800-229-5647** 8:00 am - 5:00 pm (Eastern Time), Monday through Friday.

**NOTE:** The use and installation of this product must conform to local codes. In the absence of local codes, use the National Fuel Gas Code, ANSI Z223.1/NFPA54. Reference to Natural Gas and Propane Installation Code CSA B 149 .1 or Propane Storage and Handling code B149.2

## **IMPORTANT NOTICE: READ ALL INSTRUCTIONS PRIOR TO ASSEMBLY AND USE**

### **Safety First!**

**Read and understand all warnings and precautions prior to operating your grill.**

### **WARNING**

1. This grill is for outside use only. It should not be used in a building, garage or any other enclosed area.
2. The use of alcohol, prescription or non-prescription drugs may impair an individual's ability to properly assemble or safely operate this appliance.
3. Always open the grill lid carefully and slowly as heat and steam trapped within the grill could cause severe burns.
4. Always place your grill on a hard and level surface far away from combustible materials and structures. An asphalt or blacktop surface may not be acceptable for this purpose.
5. Do not leave a lit grill unattended.
6. Keep children and pets away from the grill at all times.
7. This is not a tabletop grill. Do not place this grill on any type of tabletop surface.
8. Do not use the grill in high winds.
9. This grill must be used with propane gas only (propane gas cylinder not included).
10. Do not attempt to attach this grill to the self-contained propane system of a camper, trailer, motor home or house.
11. Do not use charcoal or lighter fluid.
12. Do not use gasoline, kerosene or alcohol for lighting. The LP-gas supply cylinder must be constructed and marked in accordance with the specifications for propane gas cylinders of the U.S. Department of Transportation (DOT) CFR 49.
13. This outdoor gas appliance is not intended to be installed in or on recreation vehicle s and/or boats.
14. Do not attempt to move the grill while it is lit.
15. Do not use the grill unless it is COMPLETELY assembled and all parts are securely fastened and tightened.
16. Keep combustible items and surfaces at least 24 inches away from the grill at all times. DO NOT use this gas grill or any gas product under any overhead enclosure or near any unprotected combustible constructions.
17. Do not use in an explosive atmosphere. Keep grill area clear and free from combustible materials, gasoline and other flammable vapors and liquids.
18. Do not attempt to use or assemble with missing or damaged parts. Contact customer service for a replacement.

### **CAUTION-Prevention of Burns**

1. To avoid burns, do not touch metal parts of the grill until they have completely cooled for at least 45 minutes or unless you are wearing protective gear such as pot holders, protective gloves or mittens.
2. Do not alter the grill in any manner.
3. Clean and inspect the hose before each use. If there is evidence of abrasion, wear, cuts or leaks, the hose must be replaced prior to operation. The replacement hose assembly should be in accordance with the manufacturer's specifications .
4. Move gas hoses as far away as possible from hot surfaces and dripping hot grease.
5. Never keep a filled gas container in a hot car or car trunk. Heat will cause the gas pressure to increase, which could open the relief valve and allow gas to escape.

## Safe Locations For Use Of This Outdoor Grill

### DANGER

Never use this outdoor grill inside any building, garage, shed or breeze way, or inside any boat, trailer or recreational vehicle, to prevent a possible fire and to prevent the possibility of carbon monoxide poisoning or asphyxiation.

### WARNINGS

Do not use this appliance under overhead combustible surface or covered area (e.g., awnings, umbrellas, porches or gazebos).

Always confirm that this grill is not positioned under the overhang of a house, a garage or other structure before lighting it. An overhang will serve to deflect flare-ups and radiated heat into the structure itself, which could result in a fire.

Always confirm that this grill is positioned more than 24 inches (61 cm) away from any combustible materials or surface before lighting it, and that no gasoline or other volatile substances are stored in the vicinity of this grill. (See diagram to right).

The temperature of a grease fire or of the radiated heat might otherwise be sufficient to ignite nearby combustible or volatile substances.

Always locate this grill where there will be ample combustion and ventilation air, but never position it in the direct path of a strong wind.

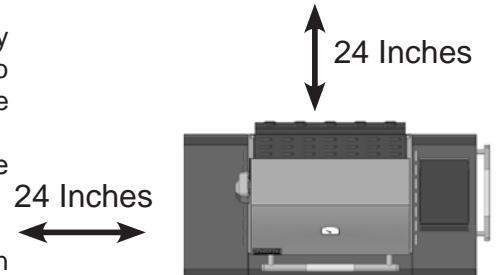

Never allow the grill to operate while unattended, to prevent uncontrolled grease fires from erupting.

Never attempt to move this grill while it is in operation or while it is still hot, to prevent possible personal injury. Never store or use gasoline or other flammable or volatile substances in the vicinity of this grill or in the vicinity of any other heat generating appliance, because of the danger of starting a fire.

Always confirm that the installation of this grill conforms with the requirements of all local codes or, in the absence of applicable local codes, with either the National Fuel Gas Code, ANSI Z223. NFPA 54 or CAN/CGA-B149.2.



Liquid propane (LP) gas is flammable and hazardous if handled improperly. Become aware of its characteristics before using any propane product.

- Propane Characteristics: Flammable, explosive under pressure, heavier than air and settles in pools in low area.
- In its natural state, propane has no odor. For your safety, an odorant has been added.
- Contact with propane could cause freeze burns to the skin.
- This grill is shipped from the factory for propane gas use only.
- Never use a propane cylinder with a damaged body, valve, collar or footing.
- Dented or rusted propane cylinders maybe hazardous and should be checked by your propane gas supplier.

### CAUTION

- It is essential to keep the grill's valve compartment, burners and circulating air passages clean.
- Inspect the grill before each use.

Step 1. Inspect all hoses and connections and make certain they are secure.

Step 2. Check and clean the burner tubes for insects and insect nests by removing the burner and inserting a bottle brush cleaner into each tube to make sure the passage is clear.

\*\*\* A clogged tube can lead to a fire beneath the grill. \*\*\*

Step 3. Ensure that the valve orifice is pointing straight and completely inserted into the burner tube.

## GENERAL INFORMATION

1. A propane gas cylinder is required for operation.
2. This gas grill is NOT intended for commercial use.

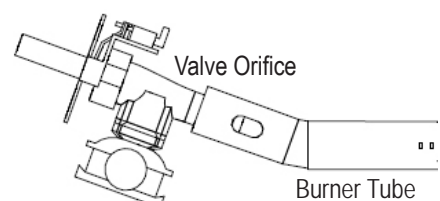

# Grill Features

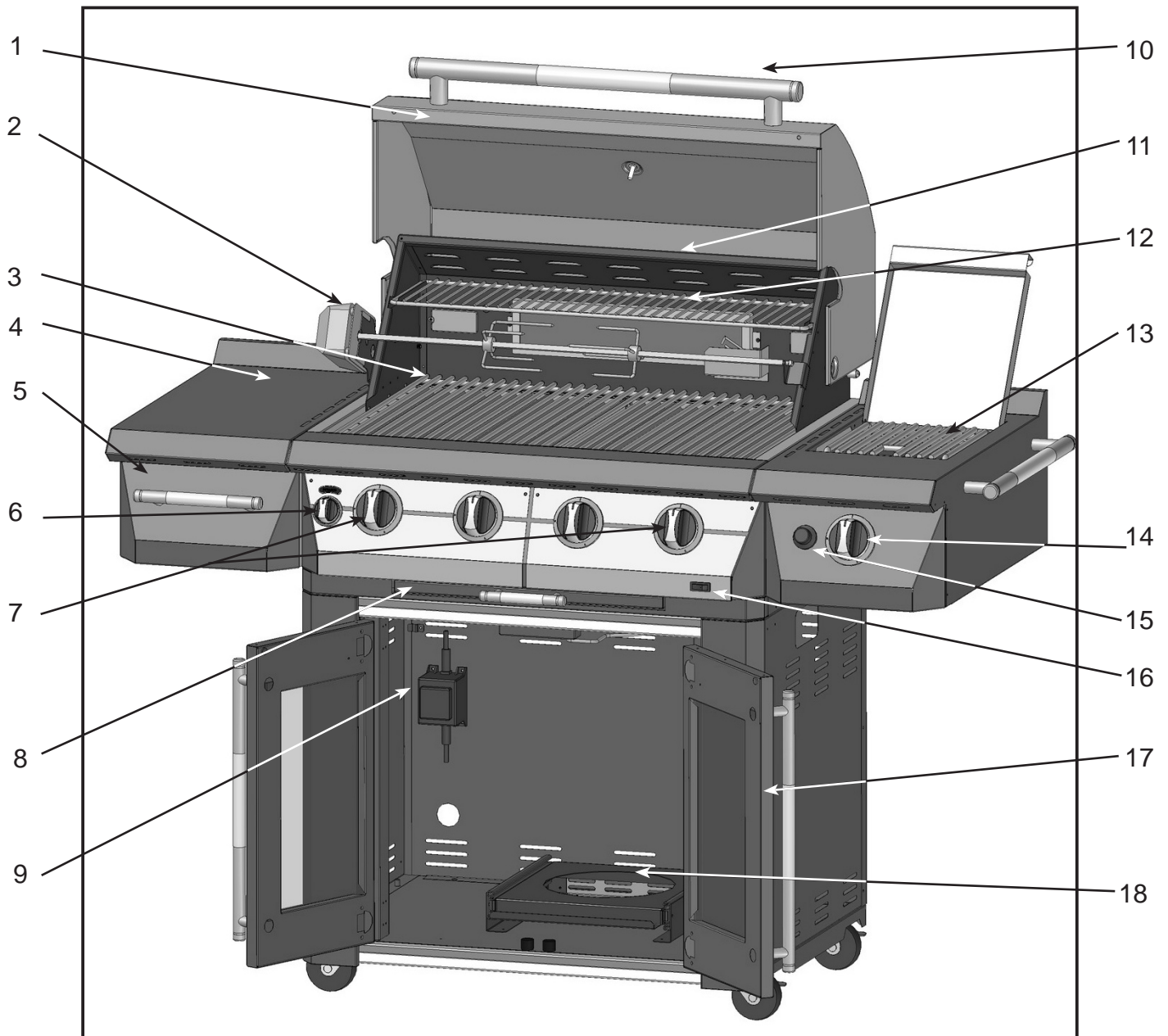

- |                                       |                               |
|---------------------------------------|-------------------------------|
| 1. Roll top grill hood                | 11. Bread warming rack        |
| 2. Rotisserie kit                     | 12. Rear Infrared burner      |
| 3. Grilling/cooking surface           | 13. Side burner               |
| 4. Side shelf                         | 14. Control Knob: Side burner |
| 5. Storage drawer                     | 15. Push button igniter       |
| 6. Control knob: Rear infrared burner | 16. Grill light switch        |
| 7. Control knobs: Main burners        | 17. Cart with glass doors     |
| 8. Drip pan                           | 18. Roll out LP tank tray     |
| 9. Power transformer                  |                               |
| 10. Hood Handle                       |                               |

# Getting Started

---



Self-tapping screw x 2



Phillips pan head screw x 2

## Getting Started

1. Please follow the steps in the order that they are presented.
2. Assemble the grill where you plan to use it.
3. You may want to place an old towel or cloth at the assembly site to prevent nuts and bolts from becoming lost.
4. Have a friend help. An assistant can make the assembly easier by holding the parts in place while you fasten the nuts and bolts.
5. To be ready to barbecue immediately, have a L.P. gas cylinder filled by an authorized L.P. dealer or cylinder exchange center.

## Unpacking the Grill Parts

1. Remove and set aside all inner boxes and parts from the master carton.
2. Remove and set aside all wrapping paper and additional packaging from the parts.
3. Do not destroy carton or packing until your grill is completely assembled and operating to your satisfaction.

## Tools needed to assemble grill:

Phillips screwdriver  
Adjustable wrench  
1/2" wrench or socket  
1/4" nut driver or socket

## TOOLS NOT INCLUDED

### **WARNING**

Failure to follow all Danger, Warnings, and For Your Safety notices in this Grill Guide may result in serious bodily injury or death, fire or an explosion causing damage to property.

### **DANGER**

Perform a Gas Leak Test explained later in this Grill Guide before operating your grill.

# Grill Assembly

## LEFT SHELF ASSEMBLY

1. Pull the drawer all the way out, press the black plastic drawer slide release levers to remove the drawer. (See Fig. 1)

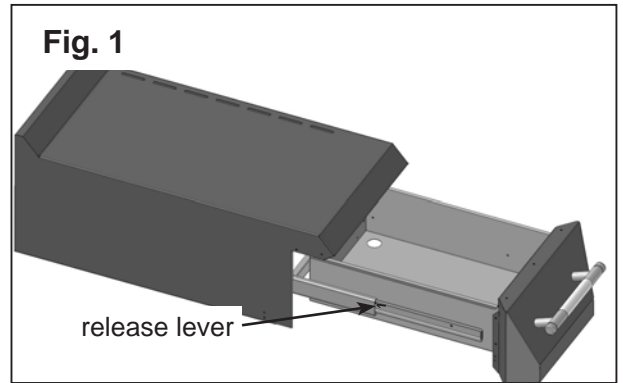

2. Loosen the four hex head bolts on the side of the grill by approximately 1/4". (See Fig. 2)

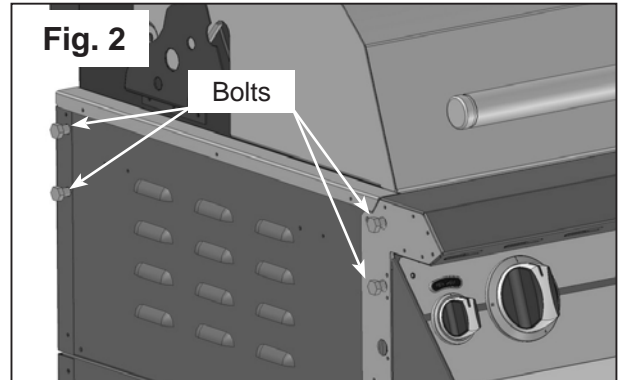

3. Attach the left shelf by inserting the four bolt heads into the holes on the left shelf. Tighten the bolts securely with a 1/2" wrench. (See Fig. 3)

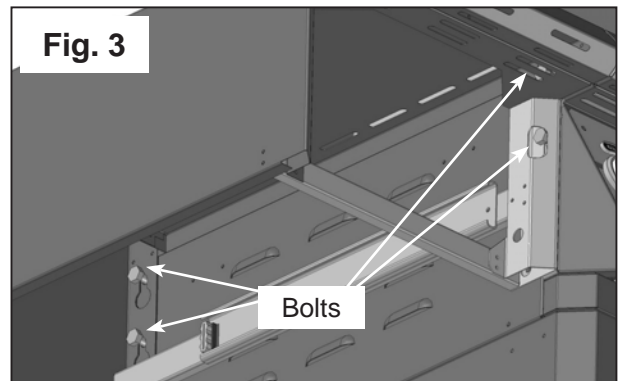

4. Install a self tapping screw through the slotted hole on the front bottom of the side shelf to the left side of the grill. (See Fig. 4)

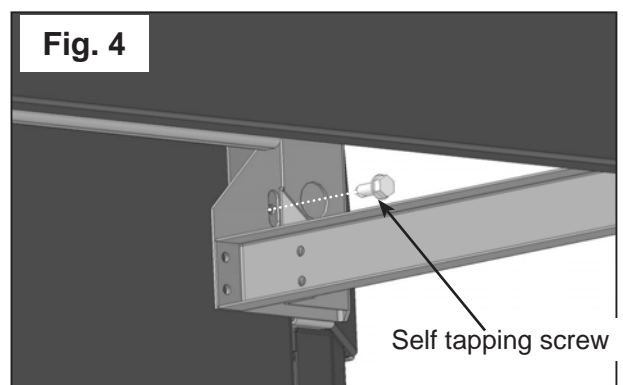

5. Re-install the drawer into the shelf. Be sure to line up the drawer slides as you re-insert the drawer back into the shelf. (See Fig. 5)

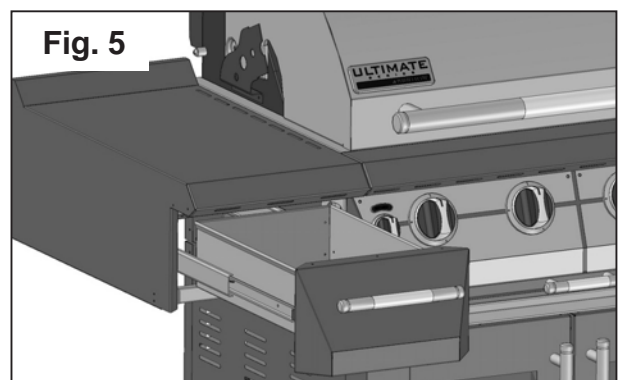



# Grill Assembly

## SIDE BURNER PARTS ASSEMBLY

1. Remove side burner valve assembly from packaging. Feed the valve assembly through the large cut out in the side of the cart. Loosen the four hex head bolts on the side of the grill by approximately 1/4". Attach the side burner by inserting the four bolt heads into the holes on the side burner. Tighten the four bolts securely with a 1/2" wrench. (See Fig. 6)

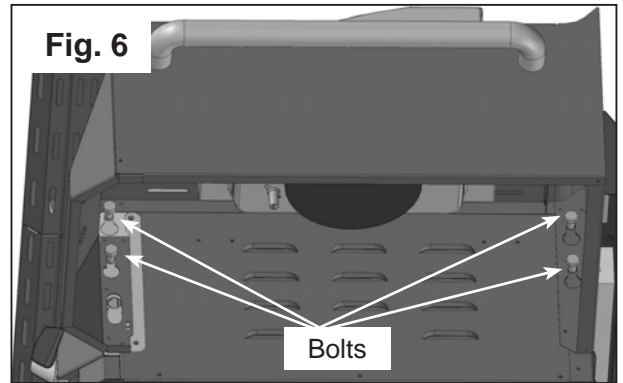

2. Install a self tapping screw through the slotted hole on the front bottom of the side shelf to the right side of the grill. (See Fig. 7)

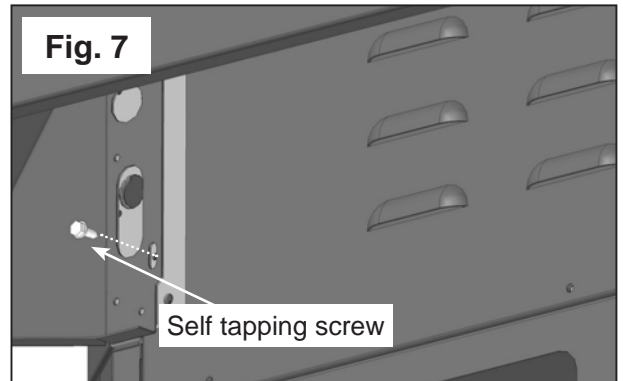

3. Unscrew the push button igniter cap from the igniter module. Insert the neck of the igniter module through the open hole on the side burner shelf. Use the plastic nut to secure it. Install the battery with the positive side facing outward. Replace and tighten the push button igniter cap. (See Fig. 8)

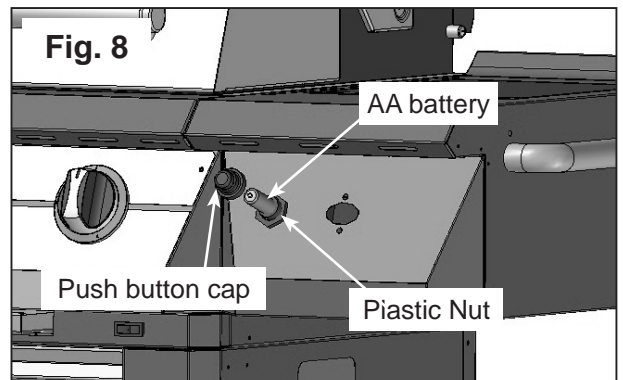

4. Connect loose igniter wires from the grill to the open terminals of the igniter. (See Fig. 9)

**Note: The igniter is designed in such a way that it does not matter which terminal tab is used when connecting igniter wires.**

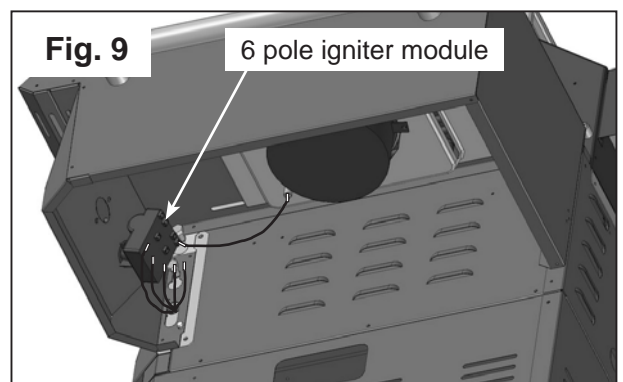

5. Remove the two phillips pan head M5 x 10 screws from the orifice bracket. Align the orifice into the center of the side burner bracket. (See Fig. 10)

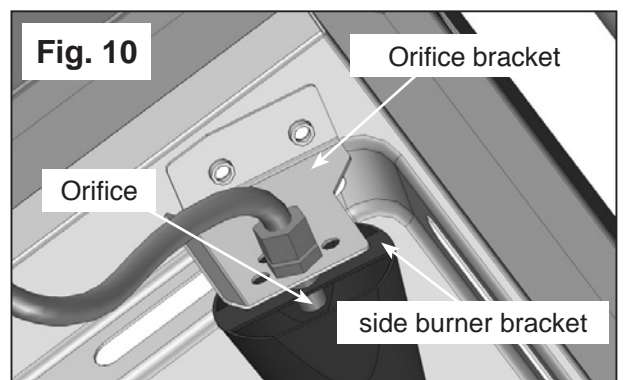

# Grill Assembly

## **SIDE BURNER PARTS ASSEMBLY**

6. Use two screws removed in step 5 to secure the orifice bracket on the side burner tray. (See Fig. 11)

**Note:** Add lock washer when installing the screws in position.

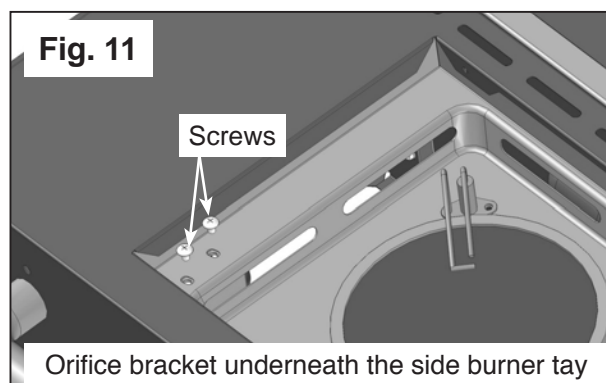

7. Slide the side burner valve stem through the center hole in the front of the shelf. Insert one valve screw through the bezel and in to the side burner valve and tighten. Next, install the second valve screw through the bezel and tighten. Make sure the bezel is installed with the "OFF" position facing up. Install control knob, making sure to line up the flat side of the valve stem with the flat side of the knob stem. (See Fig. 12)

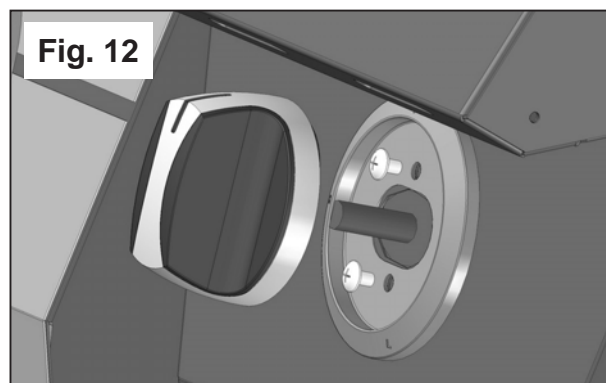

8. Place the side burner grate in position. (See Fig. 13)

**Note:** Remove all the tape before using the grill.

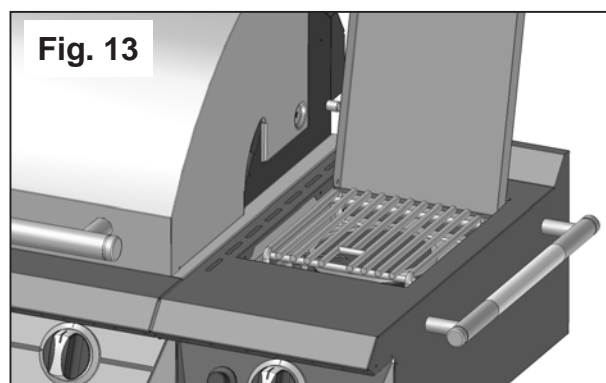

# Grill Assembly

## INTERIOR PARTS ASSEMBLY

1. Place the flavor grids in position. (See Fig. 14)
2. Place the anti-flare screen mesh in position. (See Fig. 15)
3. Place the main cooking grates in position. (See Fig. 16)
4. Slide the Bread Warming Rack through the cutouts on the hood support sides and rest it on the brackets. (See Fig. 17)

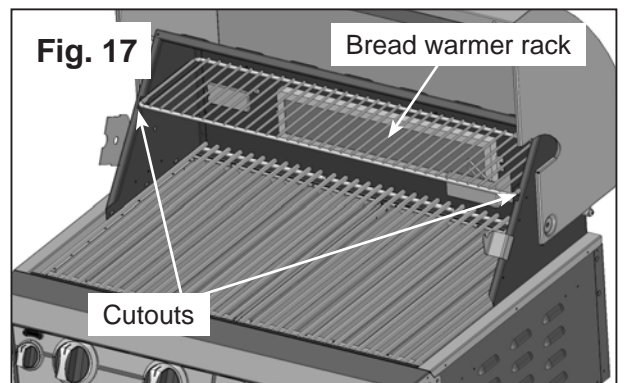
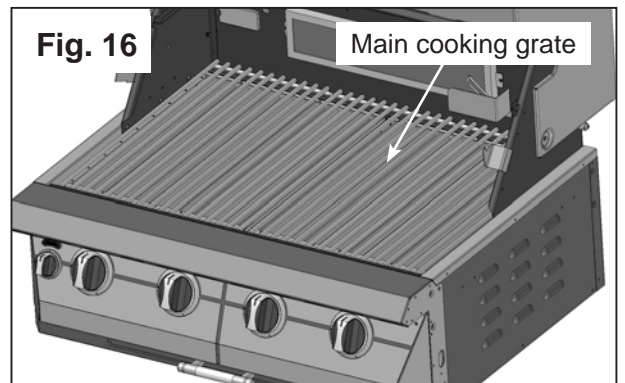
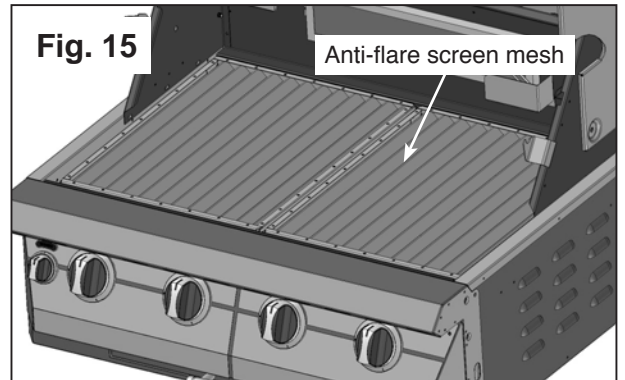
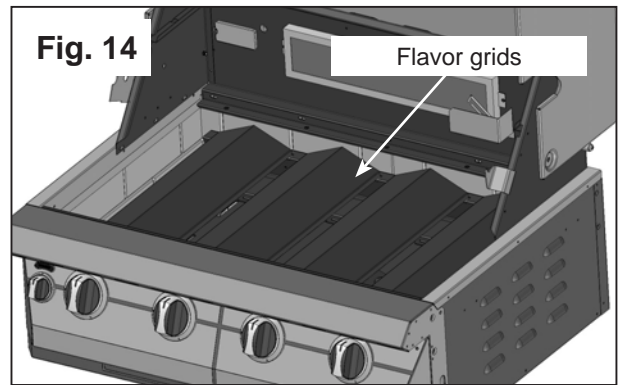

# Grill Location

## ⚠ WARNING

Do not use the grill in garages, breezeways, sheds or any enclosed area. Never operate the grill in enclosed areas as this could lead to a carbon monoxide buildup, which could result in injury or death. Place the grill on a level surface. Avoid moving the grill while it is in operation.

**NOTE: The grill will operate best if it is not facing directly into the wind.**

Clearance to combustible construction - A minimum of 24" from the sides and back must be maintained from the gas grill above and below the cooking surface to adjacent vertical combustible construction.

Clearance to non-combustible construction - A minimum of 10" clearance from the back of the grill to non-combustible construction is required for the lid to fully open.

Storage of an outdoor gas cooking appliance indoor is permissible only if the cylinder is disconnected and removed from the appliance.

## ⚠ WARNING

Heat and smoke exhaust out of the back of the grill hood opening. Make sure not to have the grill back facing your home or anything that could be damaged by heat or smoke.

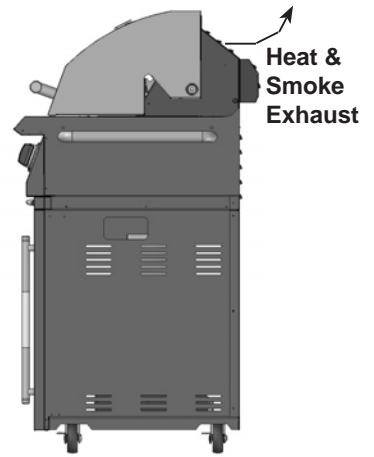

## GENERAL RULES

**Do not leave the grill unattended while cooking!**

1. Make sure the grill has been leak tested and is properly located.
2. Light the grill burners using the instructions provided in this manual.
3. Turn the control knobs to desired temperature "High, Medium, or Low" and preheat the grill for 10 minutes before cooking.
4. Adjust heat settings to meet your cooking needs for desired results.
5. Allow grill to cool down, wipe off any splatters or grease and clean the drip tray as needed.
6. Do not put a cover on the grill while it is still hot as it could start a fire.

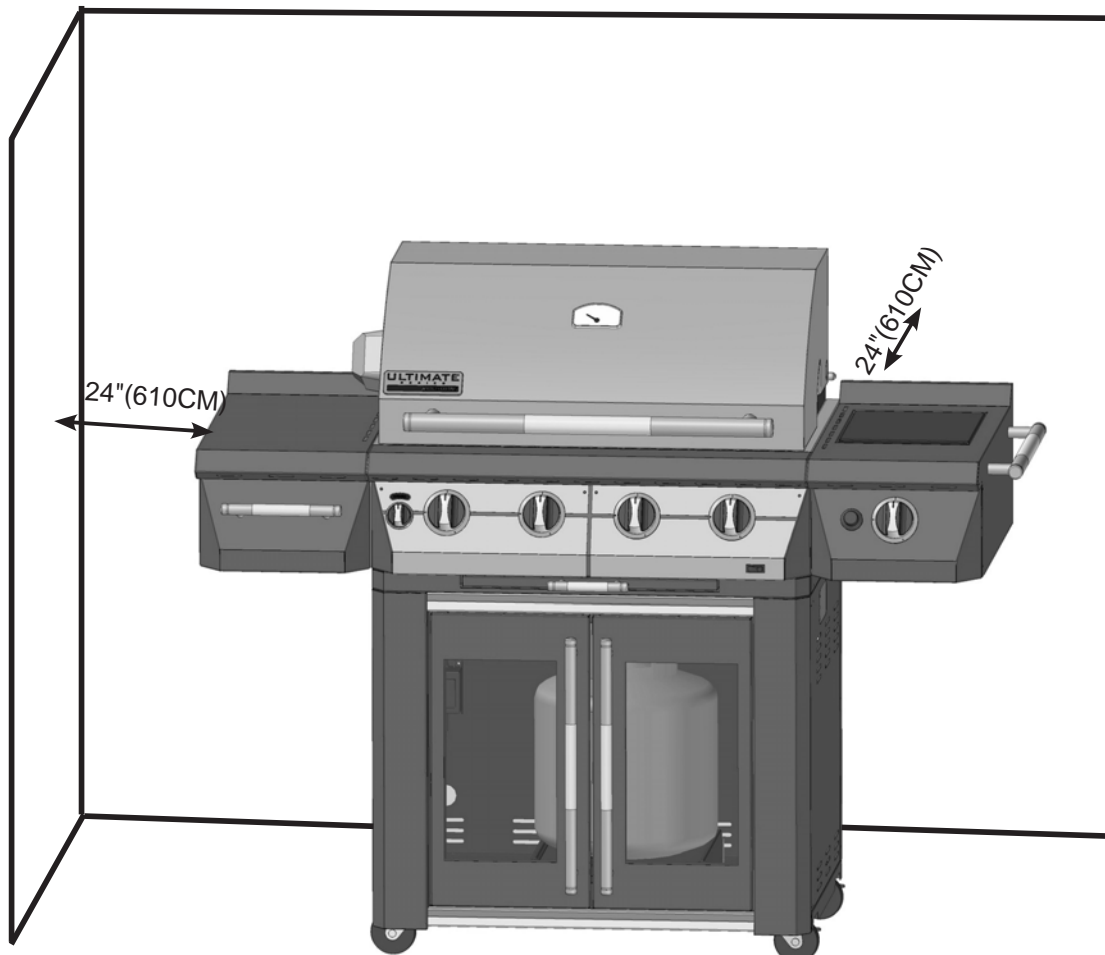

# Gas Requirements

---

## GENERAL INFORMATION

---

 **WARNING** Never attach an unregulated gas line to the appliance. Connection to an unregulated gas line can cause excessive heat or fire.

Verify the type of gas supply to be used, either Natural Gas (N.G.) or Liquid Propane (L.P.), and make sure the serial plate agrees with that of the supply. Conversion kits are available separately for an additional cost which will enable you to convert your grill from L.P. to N.G. or to convert your grill from N.G. to L.P. Please see your local dealer for more information.

 **WARNING** Always have a qualified service technician perform difficult conversions or modifications.

For natural gas installations, an installer must supply a gas shutoff valve that is easily accessible to the grill. All installer supplied parts must conform to local codes, or in the absence of local codes, with the National Electrical Code, ANSI/NFPA 70- 2002, and the National Fuel Gas Code, NFPA 54-2002/ANSI Z223.1-2002.

All pipe sealants must be an approved type and resistant to the actions of L.P. gases. Never use pipe sealant on flare fittings. All gas connections should be made by a competent qualified service technician and in accordance with local codes and ordinances. In the absence of local codes, the installation must comply with the National Fuel Gas Code, NFPA 54-2002/ANSI Z223.1-2002. Gas conversions kits may be purchased separately. When ordering gas conversion kits, have the model number, and the type of gas (N.G. or L.P.) used for your grill.

This grill and its individual shut off valve must be disconnected from the gas supply piping system during any pressure testing of that system at test pressures in excess of 1/2 PSIG (3.5 kPa.).

This grill must be isolated from the gas supply piping system by closing its individual manual shut-off valve during any pressure testing of the gas supply piping system at test pressures equal to or less than 1/2 PSIG (3.5 kPa.).

The installation of this grill must conform with local codes, or in the absence of local codes, with National Fuel Code, NFPA 54-2002/ANSI Z223.1a-2002.

Installation in Canada must be in accordance with the Standard CSA B149.1 or B149.2 (installation code for gas burning appliances and equipment) and local codes.

# Gas Requirements

## L.P. GAS INSTALLATION

Perfect Flame™ Gas Grills that are set to operate with L.P. gas come with a high capacity hose and regulator assembly. **(Note: Only use the pressure regulator and hose assembly supplied with the grill or a replacement pressure regulator and hose assemblies specified by the manufacture).** This assembly is designed to connect directly to a standard 20 lb. L.P. cylinder. L.P. Cylinders are not included with the grill. L.P. Cylinders they can be purchased separately at an independent dealer.

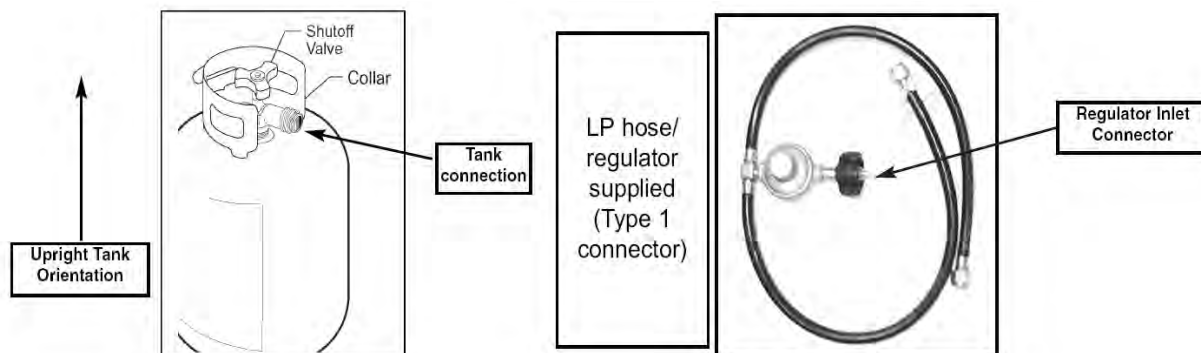

## L.P. TANK INFORMATION

Never use a dented or rusted L.P. tank or cylinder with a damaged valve.

L.P. cylinders are equipped with an O.P.D (Overfilling Prevention Device). The device shuts off the flow of gas to a cylinder after 80% capacity is reached. This limits the potential for release of gas when the cylinder is heated, averting a fire or possible injury.

The L.P. cylinder must have a shut-off valve terminating in an L.P. gas supply cylinder outlet specified, as applicable, for connection No. 510 in the standard for compressed gas cylinder valve outlet and inlet connection ANSI/CGA-V-1. Cylinders must not be stored in a building, garage, or any other enclosed area. (The L.P. cylinder must have an overfill protection device, OPD, and a collar to protect the cylinder valve.)

The L.P. gas supply cylinder must be constructed and marked in accordance with the specifications for L.P. gas cylinders of the U.S. Department of Transportation (DOT) or the National Standard of Canada, CAN/CAS-B339, "Cylinders, Spheres and Tubes for the Transportation of Dangerous Goods and Commission."

## L.P. TANK USE

- **When turning the L.P. tank on, make sure to open the valve SLOWLY two (2) complete turns to insure proper gas flow. Most gas tanks now come equipped with a leak detector mechanism internal to the tank, when gas is allowed to escape rapidly it shuts off the gas supply. Opening the valve rapidly may simulate a gas leak, causing the safety device to activate, restricting gas flow causing low flames. Opening the valve slowly will insure this safety feature is not falsely triggered.**
- When not in use, gas supply cylinder valve is to be in the "OFF" position.
- The tank supply system must be stored upright to allow for vapor withdrawal.
- The regulator and hose assembly must be inspected before each use of the grill. If there is excessive abrasion or wear or if the hose is cut, it must be replaced prior to the grill being used again.
- Cylinders must be stored outdoors out of the reach of children and must not be stored in a building, garage or any other enclosed area.
- Only a qualified gas supplier should refill the L.P. tank.
- Place dust cap on cylinder valve outlet whenever the cylinder is not in use. Only install the type of dust cap on the cylinder valve outlet that is provided with the cylinder valve. Other types of caps or plugs may result in leakage of propane.

### **▲ WARNING**

**DO NOT** store a spare L.P. gas cylinder under or near the grill. Never fill the cylinder beyond 80% full.

**If this information is not followed exactly, a fire causing death or serious injury may occur.**

# Pre Operation Leak Testing

---

## **GENERAL INFORMATION**

Although all gas connections on the grill are leak tested prior to shipment, a complete gas tightness check must be performed at the installation site due to possible shifting during shipment, installation or excessive pressure unknowingly being applied to the unit. Periodically check the whole system for leaks and immediately check the system if the smell of gas is detected.

## **BEFORE TESTING**

1. Do not smoke while leak testing.
2. Extinguish all open flames.
3. Never leak test with an open flame.
4. Mix a solution of equal parts mild detergent or liquid soap and water.

## **TESTING**

1. Turn off the burner control knobs.
2. Turn the top knob of the fuel supply cylinder counter-clockwise (right to left) two (2) rotations to open.
3. Apply the soap solution to connections of the fuel supply assembly. If no soap bubbles appear, there is no gas leak. If bubbles form at the connections, a leak is detected. If a leak is detected, immediately turn off the gas supply, tighten any leaking fittings, turn gas on, and repeat steps 1-3.
4. Turn off the knob on the fuel supply cylinder.
5. Turn on the burner control knobs for a moment to release the pressure in the hose, then turn the control knobs back off.
6. Wash off soapy solution with cold water and towel dry.

Check all gas supply fittings before each use and each time the gas supply cylinder is connected to the regulator. Have a qualified service technician leak test the grill any time a part of the gas system is replaced.

Also it is recommended to perform a leak test at least once a year whether or not the L.P. gas supply cylinder has been disconnected.

## **WARNING**

**When leak testing this appliance, make sure to test and tighten all loose connections, including the side burner. A slight leak in the system can result in a low flame, or hazardous condition. Most L.P. gas tanks now come equipped with a leak detector mechanism internal to the tank, when gas is allowed to escape rapidly, it shuts off the gas supply. A leak may significantly reduce the gas flow making the grill difficult to light or causing low flames.**

## **WARNING**

**If you cannot stop a gas leak turn off the gas supply and call your local gas company or the dealer you purchased the appliance from. If necessary, replace the faulty part with the manufacturer's recommended replacement part. A slight leak could cause a fire.**

# Lighting the Grill

**Do not attempt to "Light" the grill if the odor of gas present!!**

## BEFORE LIGHTING

### **⚠ WARNING** Important! Before Lighting:

- Check the gas supply line for cuts, wear or abrasion.
- Always keep your face and body as far away from the grill as possible when lighting.

## GRILL BURNER LIGHTING

### Lighting the Grill with electronic igniter

1. Make sure all control knobs are in the "OFF" position.
2. Open the gas supply valve located on top of your L.P. tank.

**ATTENTION:** When turning the L.P. tank on, make sure to open the valve very **SLOWLY** two (2) complete turns to insure proper gas flow.

3. Always open the hood before attempting to light.
4. Push and turn one of the control knobs counter-clockwise to the "HIGH" position and immediately press the electronic igniter button. You will hear a snapping sound. It may be necessary to hold the electronic starter button for about 4 seconds. (See Fig. 18)

**NOTE:** If the burner does not light in 4 seconds, turn the knob to the "OFF" position and wait 5 minutes before trying again.

5. Repeat above steps to light remaining burners.

### Match Lighting

If by chance the electronic igniter does not light the burner, the burner may be lit with a match attached to the match extender, located on the inside of the cart door.

Remove the main cooking grate, anti-flare screen flavor grid, Keep your face as far away from the grill surface as possible and pass the match extender to the ports of the main burner tubes. Position the match near the burner ports and push and turn the control knob counter-clockwise to the "HIGH" position. After the burner has lit, turn the knob to the "LOW" position and carefully place the flavor grid screen and grate back in position. Then turn the control knob to the desired setting. (See Fig. 19-21)

### **NOTE:**

**If the grill will not light after several attempts see the trouble-shooting section of this manual. Turn the control knobs to the OFF position when not in use.**

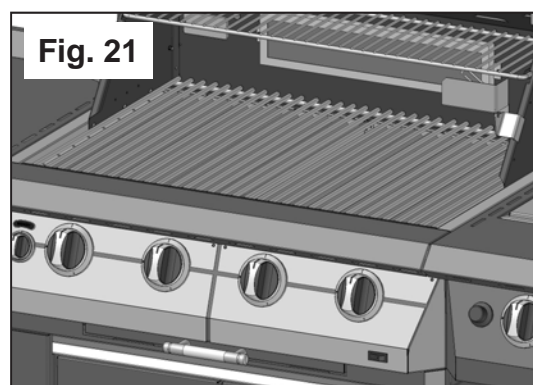
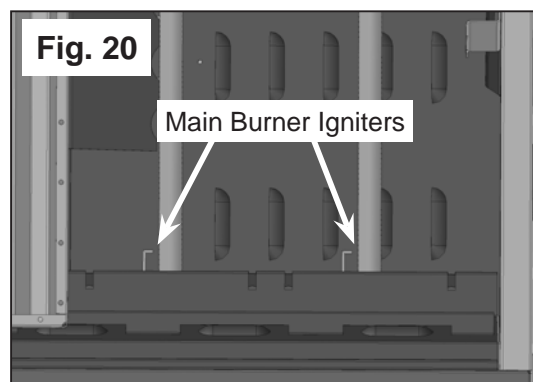
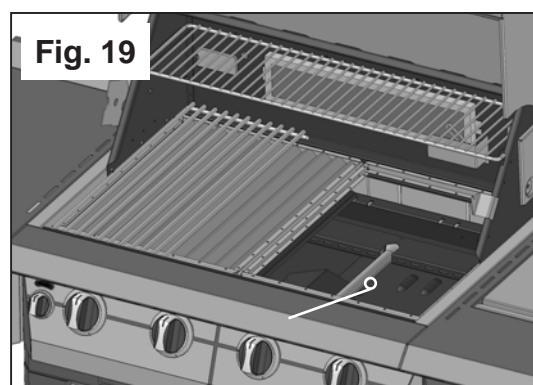
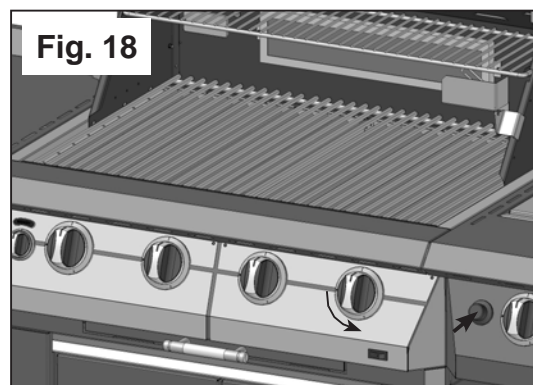



# Using the Rotisserie Burner

The grill rotisserie system is designed to cook items from the back using infrared heat. The rotisserie burner is an infrared type which provides intense searing radiant heat. Preferred by chefs over other cooking methods, this intense heat sears in the natural juices and nutrients found in quality cuts of meats.

**Remove the warming rack from the grill when using the rotisserie to prevent warping from the intense heat of the infrared unit.**

**NOTE:** The rotisserie spit rod is centered between the grill hood and the burners. It may be necessary to remove the grates, anti-flare screen flavor grids when cooking larger portions of meat on the rotisserie. This is by design, since this configuration gives you the most possible room above and below the rod for larger pieces of meat.

Once lit, the rotisserie burner will reach cooking temperature in 1 minute. The orange/red glow will even out in about 5 minutes. The rotisserie motor is equipped with metal gears and is capable of turning up to 8 lbs. of food. The motor is mounted on a bracket on the left side of the grill by sliding the motor over the bracket with the cord facing the back of the grill. Make sure the rotisserie motor is completely seated on the bracket prior to operating. Make sure the rotisserie cord is away from any hot surfaces.

## **⚠ WARNING Electrical Grounding Instructions**

**This appliance (rotisserie motor) is equipped with a three-prong (grounding) plug for your protection against shock hazard and should be plugged directly into a properly grounded three-prong receptacle. Do not cut or remove the grounding prong from this plug.**

## **ATTACHING THE ROTISSERIE**

The motor is mounted on a bracket on the left side of the grill by sliding the motor over the bracket with the cord facing the back of the grill. (See Fig. 25)

With the rotisserie motor in place and plugged into an electrical outlet, it is now ready to operate. Slide one of the meat forks onto the rod (prongs facing away from the rounded end). Push the rod through the center of the food, then slide the second meat fork onto the rod (prongs toward the food). Center the food to be cooked on the rod, then push the meat forks firmly together. Tighten the thumb screws. It may also be necessary to wrap food with butcher's string, (never use nylon or plastic string) to secure loose portions. (See Fig. 26)

Once the food is secure, insert the pointed end of the rotisserie rod into the motor assembly and rest the other end on the support on the right-hand side of the grill. (If needed, remove the cooking grates, anti-flare screen and flavor grids for more room). Turn the power switch to the "ON" position to start the rotisserie motor.

**NOTE:** Remove the rotisserie when not in use. Store the unit indoors when not in use. Remove warming shelf when using rotisserie.

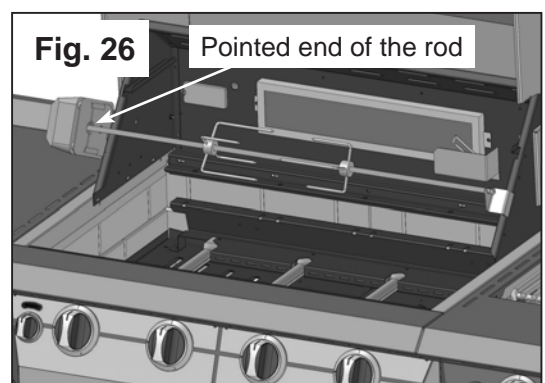
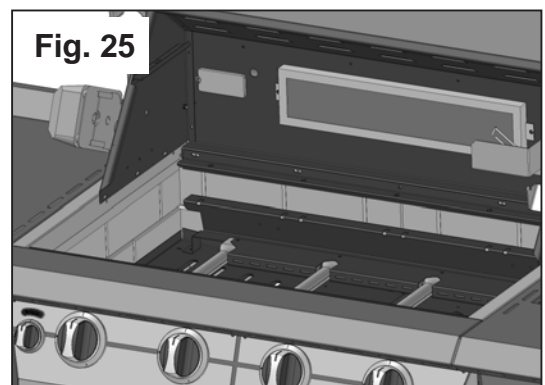

**⚠ WARNING**  
**Do not use the rotisserie in the rain.**

# Rotisserie Lighting

## ROTISSERIE LIGHTING

Open the lid. Push and turn the control knob for the rotisserie counter-clockwise to the "HIGH" position. **Continue push the knob and wait 5 seconds.** You'll hear a snapping sound. If the burner does not light in 4 seconds, turn the control knob to "OFF" and wait 5 minutes before trying again. Once lit, turn the control knob to the desired setting. (See Fig. 27)

If the igniter does not function, the burner can be lit by holding a lit match to the burner while the control knob is turned counter-clockwise to "HIGH". (See Fig. 28)

**NOTE: After the first use the stainless steel around the burner will darken. This is a normal reaction of premium stainless steel due to heat and is not a defect. The infrared panel will also darken after initial use. This is also a normal occurrence.**



**NOTE: Do not operate the main burners and infrared back burner at the same time. This can cause warping of the roll top grill hood.**

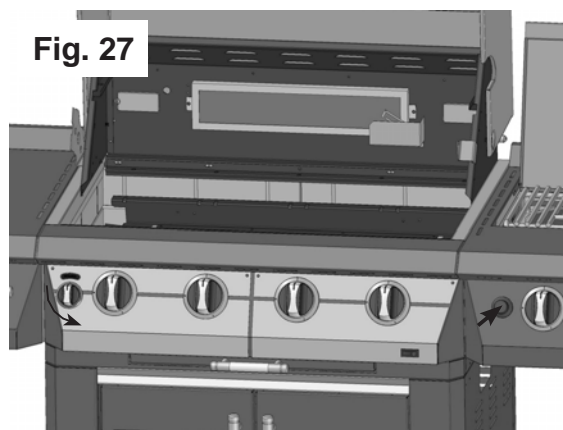

Fig. 27

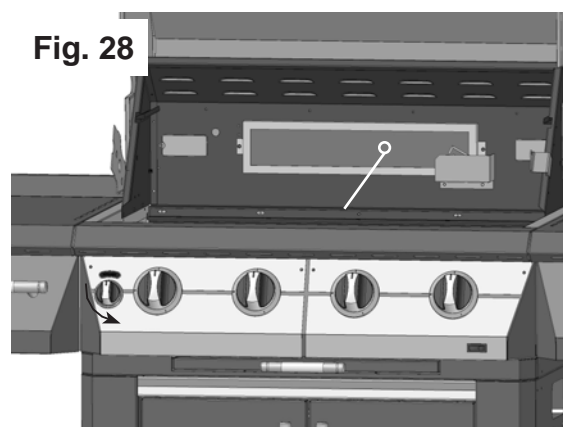

Fig. 28

## Lighting Side Burner



**Keep any electrical supply cords and the fuel supply away from any heated surfaces.**

## SIDE BURNER LIGHTING

Push and turn the control knob to the "HIGH" position. Continue push the knob. You'll hear a snapping sound. It may be necessary to hold the knob for about 4 seconds. If the burner does not light in 4 seconds, turn the knob to the "OFF" position and wait 5 minutes before trying again. (See Fig. 23)

## MATCH LIGHTING

If by chance the electronic igniter does not light the burner, the burner may be lit with a match. Attach the match to the match extender, located inside the right cart door.

Keep your face as far away from the grill surface as possible and hold a match, attached to the match extender, near the burner ports, then push and turn the control knob counter-clockwise to the "HIGH" position. Once lit, turn the control knob to the desired setting. (See Fig. 24)

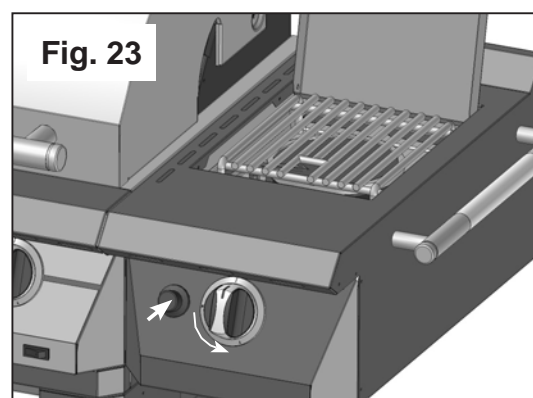

Fig. 23

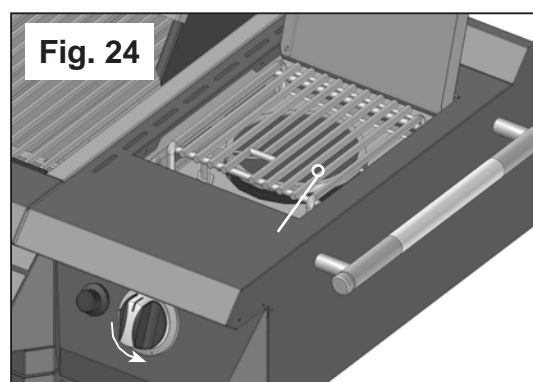

Fig. 24

# Grill Light Maintenance

---

The light bulb in your grill will need to be replaced occasionally. **Only use the light bulb supplied with the grill or a replacement lamp specified by the manufacture.**

## Light bulb replacement instructions:

- 1, Unplug the light cord.
- 2, Open the lid, remove the self-tapping screw holding the glass cover in place.
- 3, Remove glass cover and light bulb.
- 4, Reinstall the new light bulb, glass cover and screw.



## **⚠ WARNING**

**Always unplug light cord when not in use.**

## **⚠ WARNING**

**Do Not use grill light in the rain.**

# Care and Maintenance

---

**IMPAIRED VENTILATION OF HOT AIR FROM GRILL** - In order for the burners to function properly, hot air created by the burners must have a way to escape, the burners may become deprived of oxygen, especially if the burner output is set at HIGH. This is the reason your grill was designed with ventilation louvers. These design features give the hot air an escape route. Accordingly, never operate your grill with very little or no open space at the cooking surface (the cooking grids provide sufficient space). Also, never cover the ventilation louvers with foil or other materials that prevent air flow. Specifically, do not cover the entire surface with foil, a large pan, etc.

## GENERAL MAINTENANCE

- Keep outdoor cooking gas appliance area clear and free from combustible materials, gasoline and other flammable vapors and liquids.
- Do not obstruct the flow of combustion and ventilation air.
- Keep the ventilation openings of the cylinder enclosure free and clear from debris.
- Visually check the burners

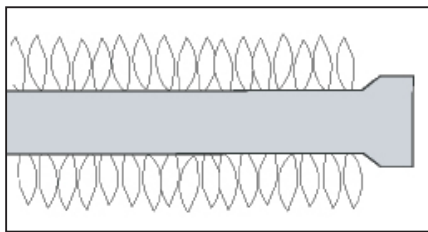

**Normal:** Soft blue flames

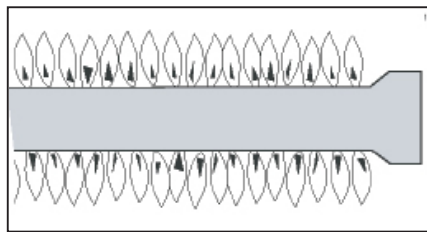

**Out of Adjustment:** Hard blue flames- too much air

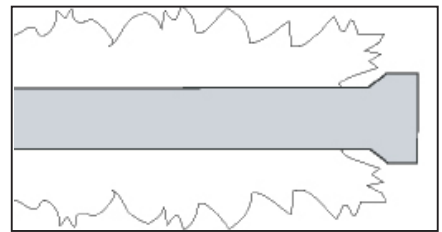

**Poor Combustion:** wavy, yellow flames- too little air

## GENERAL CLEANING

**IMPORTANT:** Before cleaning, make sure all controls are off and the grill is cool. Always follow label instructions on cleaning products.

For routine cleaning, wash with soap and water using a soft cloth or sponge. Rinse with clean water and dry at once with a soft, lint-free cloth to avoid spots and streaks.

To avoid scratching the surface, do not use steel wool to clean the grill.

Use the vinyl grill cover to protect finish from weather.

# Care and Maintenance

---

## **DRIP TRAY**

The drip tray should be cleaned periodically to prevent heavy buildup of debris.

**NOTE: Allow the drip tray to cool before attempting to clean.**

**Important: Do not leave the grill outside during inclement weather unless it is covered. Rain water can collect inside of the grill, the grill cart or the drip tray if left uncovered. If the drip tray is not cleaned after use and the grill is left uncovered, the drip tray will fill with water causing grease and water to spill into the grill cart. We recommend cleaning and storing the drip tray after every use.**

## **COOKING GRATES**

The cooking grates can be cleaned immediately after cooking is completed and after turning off the grill. Wear a barbecue mitt and scrub the cooking grates with a damp cloth. If the grill is allowed to cool down, cleaning the grates will be easier if removed from the grill and cleaned with a mild detergent.

## **STAINLESS STEEL**

After initial usage, areas of the grill may discolor from the intense heat given off by the burners, this is normal.

Purchase a mild stainless steel cleaner and rub in the direction of the grain of the metal. Specks of grease can gather on the surface of the stainless steel and bake on to the surface and give a worn appearance. For removal, use a non-abrasive oven cleaner in conjunction with a stainless cleaner.

**NOTE: Always scrub in the direction of the grain.**

## **IGNITER ACCESS (UNDER SIDE BURNER SHELF)**

To remove igniter, unscrew igniter push button and locking nut from front panel of the side burner and igniter will fall out through the bottom.

## **PORCELAIN PARTS**

Certain parts of your grill have a porcelain coating. Porcelain is a glass-based product, and is highly durable to standard wear and tear. However, porcelain is sensitive to concussive blows, which can create interlaced micro-fractures, or “spider-webs.” Please take care not to strike any porcelain covered parts with solid objects, drop them, or create any other concussive blows. These interlaced micro-fractures are common and may lead to minor chipping. Neither the chipping nor the interlaced micro-fractures will adversely affect the performance of your grill, and are not covered under the warranty for porcelain parts.

# Troubleshooting Guide

<b>Problem</b>	<b>Possible Solution</b>
Grill will not light	<ol style="list-style-type: none"> <li>1. Push the igniter button and check for sparks.</li> <li>2. If there is a spark, check to make sure gas is supplied to the burner.               <ol style="list-style-type: none"> <li>a. Purge the line of any trapped air.</li> <li>b. Check to see if you can match-light the burner.</li> <li>c. Check to see that the other burners operate.</li> <li>d. Visually check the electrode and wire while pushing the igniter button. If a spark occurs anywhere but the ignitor trip, the ignitor must be replaced.</li> </ol> </li> </ol>
Burner flame is yellow and gas odor can be smelled	<ol style="list-style-type: none"> <li>1. Check the burner inlet for obstruction, especially for spiders and other insects.</li> <li>2. Check the air shutter for proper adjustment.</li> <li>3. Check for the source of gas leaks.</li> </ol>
Excessive flare-ups	<ol style="list-style-type: none"> <li>1. Hood up when grilling.</li> <li>2. Keep knobs on low.</li> <li>3. Turn one burner off if necessary.</li> <li>4. Post heat grill for 10-15 minutes, this will burn off drippings.</li> <li>5. Use meats containing less fat.</li> <li>6. Always grill chicken on low, meat side down for 20 minutes and turn to skin side for another 20 minutes. follow above steps.</li> <li>7. If flare up continues, move meats to warming rack until flame sttles down.</li> <li>8. Never spray water on gas flames - it will destroy your grill.</li> </ol>
Burner blows out	<ol style="list-style-type: none"> <li>1. Check for any burner defects.</li> <li>2. Check for proper burner installation.</li> <li>3. Make certain the fuel mixture is not too lean.</li> <li>4. Make sure the gas supply is sufficient.</li> <li>5. See if the LP tank is empty.</li> </ol>

# Troubleshooting Guide

<b>Problem</b>	<b>Possible Solution</b>										
Low heat, LP gas	<p>The propane regulator assembly incorporates an excess flow device designed to supply the grill with sufficient gas flow under normal conditions, yet control excess gas flow. Rapid changes in pressure can trigger the excess flow device, providing a low flame and low temperature. If the tank valve is turned open to allow gas flow while a burner valve is open, the surge of pressure will cause the device to activate. The device will remain closed until the pressure is equalized. This should occur within 5 seconds.</p> <p>To ensure this does not cause difficulty in lighting the grill, follow these instructions:</p> <ol style="list-style-type: none"> <li>1. Make sure all burner valves are "OFF".</li> <li>2. Open the tank valve and wait 5 seconds.</li> <li>3. Light the burner one at a time following the lighting instructions.</li> </ol>										
Low heat, natural gas	<p>Gas pressure is affected by gas line and length of gas line from house gas line. Follow the recommendations in the chart below.</p> <table border="1" style="margin-left: auto; margin-right: auto; border-collapse: collapse;"> <thead> <tr> <th colspan="2" style="text-align: center;">From House to Grill</th> </tr> <tr> <th style="text-align: center;">Distance</th> <th style="text-align: center;">Tubing Size</th> </tr> </thead> <tbody> <tr> <td style="text-align: center;">Up to 25'</td> <td style="text-align: center;">3/8" diameter</td> </tr> <tr> <td style="text-align: center;">26'-50'</td> <td style="text-align: center;">1/2" diameter</td> </tr> <tr> <td style="text-align: center;">51'-100'</td> <td style="text-align: center;">2/3" of run 3/4" 1/3" of run 1/2"</td> </tr> </tbody> </table>	From House to Grill		Distance	Tubing Size	Up to 25'	3/8" diameter	26'-50'	1/2" diameter	51'-100'	2/3" of run 3/4" 1/3" of run 1/2"
From House to Grill											
Distance	Tubing Size										
Up to 25'	3/8" diameter										
26'-50'	1/2" diameter										
51'-100'	2/3" of run 3/4" 1/3" of run 1/2"										
Low heat generated with knob in "HI" position	<ol style="list-style-type: none"> <li>1. Make certain the problem is isolated to only one burner. If it appears so, clean the orifice and the burner, clearing ports of any obstruction.</li> <li>2. Check for a bent or kinked fuel hose.</li> <li>3. Make sure the air shutter is properly adjusted.</li> <li>4. Check for proper gas supply and pressure.</li> <li>5. Pre-heat the grill for full 15 minutes.</li> <li>6. If using LP gas, check for an empty tank.</li> </ol>										