



Great Outdoors™

STAINLESS

Assembly and Owner's Manual



Stainless Series Gas Grill



ASSEMBLER / INSTALLER:

Leave these instructions with the consumer.

CONSUMER / USER:

Read all of these instructions and keep them in a safe place for future reference.

FOR YOUR SAFETY

If you smell gas:

- 1 Shut off gas to the appliance.
- 2 Extinguish any open flame.
- 3 Open lid.
- 4 If odor continues, immediately call your gas supplier or fire department.

FOR YOUR SAFETY

- 1 Do not store or use gasoline or other flammable vapors and liquids in the vicinity of this or any other appliance.
- 2 An unconnected liquid propane cylinder should not be stored in the vicinity of this or any other appliance.

FOR YOUR SAFETY: Never leave a grill unattended when in use.

Statement of Commitment

Congratulations and thank you for your purchase of your new Great Outdoors grill. We are pleased that you have recognized the value of the design, function, and quality of components used in this product. We believe it is among the finest on the market.

We are committed to producing quality products that your family will enjoy for years to come. If for any reason we have failed to meet or exceed your expectations, please allow us the opportunity to make it right by calling us toll-free:

888-869-5454

between the hours of 8:00 a.m. and 4:30 p.m., central time, Monday through Friday.

We want you to be completely satisfied with your purchase so you will agree with our motto,
*“there’s nothing like...
the great outdoors.”™*



7980 East American Drive
Joplin, Missouri USA 64804
- A CFM Company -

For more information about our growing family of barbecue grills, smokers, and outdoor products, please visit our website at:

www.gogrills.com

Table of Contents

	Page Number
Chapter 1 - INSTALLATION	4
Necessary Information	4
Choosing a Safe Location	4
Liquid Propane Gas Grills	5-7
L.P. Gas Dealer Instructions	8
Chapter 2 - ASSEMBLY INSTRUCTIONS	9
Step 1 (Identifying Parts)	10
Step 2 (Assemble Pillar)	11
Step 3 (Attach Base)	12
Step 4 (Grill Head)	13
Step 5 (Side Tables)	14
Step 6 (Sideburner Knob)	15-16
Step 7 (Internal Parts)	17
Step 8 (L.P. Gas Cylinder)	18-19
Connecting an L.P. Gas Cylinder	20
Connecting to Natural Gas	21-22
Chapter 3 - USE and CARE	23
Leak Testing	24
Lighting Instructions	25-26
Side Burner Operation	27
Using Your Grill	28
Caring for Your Gas Grill	29
Cleaning and Maintenance	30
Replacement Parts	31
Chapter 4 - OUTDOOR COOKING / RECIPES	32
Recipes	33-35
Warranty	36

Stainless Series Gas Grill

Installation Chapter 1

Necessary Information to Safely Use a Gas Grill

The gas fuel used by this product is highly flammable and must be used in a responsible and cautious manner.

It is your responsibility to assemble, operate, and maintain your gas barbecue grill properly.

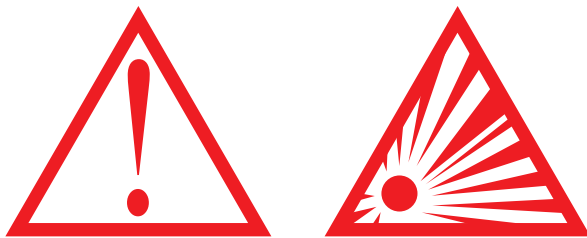

If these instructions are ignored, there is a possibility of a hazardous fire or explosion which could result in property damage, physical injury or death.

Choosing a Safe Location for a Gas Barbecue Grill

1. The gas barbecue grill may only be used for cooking out-of-doors.

- Do not operate this barbecue in garages, breeze ways, sheds or any enclosed area.

- Operating this or any gas-fired appliance in an enclosed area can produce a build-up of carbon-monoxide, which could result in injury or death.

2. Installation must conform with local codes or, in the absence of local codes, with either the National Fuel Gas Code, ANSI Z223.1, NFPA 54 (USA), or CAN/CGA-B 149.2, Propane Installation Code (Canada) and CAN/CGA-B 149.1 Natural Gas Installation Code.

To check local codes, contact your local gas dealer or gas company listed in the Yellow Pages for recommended installation procedures and regulations.

3. This appliance is not intended to be installed in or on a recreational vehicle and/or boat.

4. Keep the barbecue grill at least 24 inches (61 cm) away from any combustible construction.

- Do not use a grill under a ceiling or cover where the heat or flame could cause damage.

- Choose a level surface where the grill is not facing directly into the wind.

- Avoid moving the grill during use.

5. The grill area must be clear and free from combustible materials, gasoline, and any other flammable liquids or vapors.

- Do not use lighter fluid or charcoal briquettes in a gas grill. The flow of combustion and ventilation air is not to be obstructed. The ventilation openings of the cylinder enclosure must be kept free and clear from other debris. Do not store grill covers or other items in the cylinder area.



6. Do Not store a spare L.P. gas cylinder under or near this appliance.

Do not store an L.P. cylinder in a building, garage or any other enclosed area. Instead, store the cylinder outdoors in a well ventilated area, away from people and out of the reach of children.

7. NOT FOR USE BY CHILDREN.

- Place your barbecue grill in a location away from children and pets.
- Do not leave grill unattended when in use.

8. The outside of the barbecue grill will become hot during use.

- To avoid burns, do not touch any hot grill surface. If necessary, use a protective glove when operating control knobs, tank shut-off valve, or lid handle.
- Do not place combustible material, such as cloth or plastic, on grill surface during use.
- Do not lean on side tables or place more than 10 pounds of weight on a side table or on the open side burner table.

- 9. Make sure the heat shield and grease pan are in place under the grill bottom.**
- Heat and hot drippings from cooking food could damage the fuel supply system.

IMPORTANT: NEVER leave a grill unattended when in use.

Liquid Propane Gas Barbecue Grills

WARNING: Do not use natural gas in an appliance designed for L.P. gas. Use only liquid propane (L.P.) gas in an appliance designed for L.P. gas.

L.P. Gas

Liquid Propane (abbreviated L.P.) gas is stored under high pressure inside a cylinder and will vaporize when released. It is important that there are no leaky connections on the grill fuel supply system. Refer to the Leak Testing section of this manual.

The L.P. Fuel Supply System

An L.P. gas grill requires a fuel delivery system made up of a L.P. gas supply cylinder, a fuel regulator with hose and a gas-control valve.

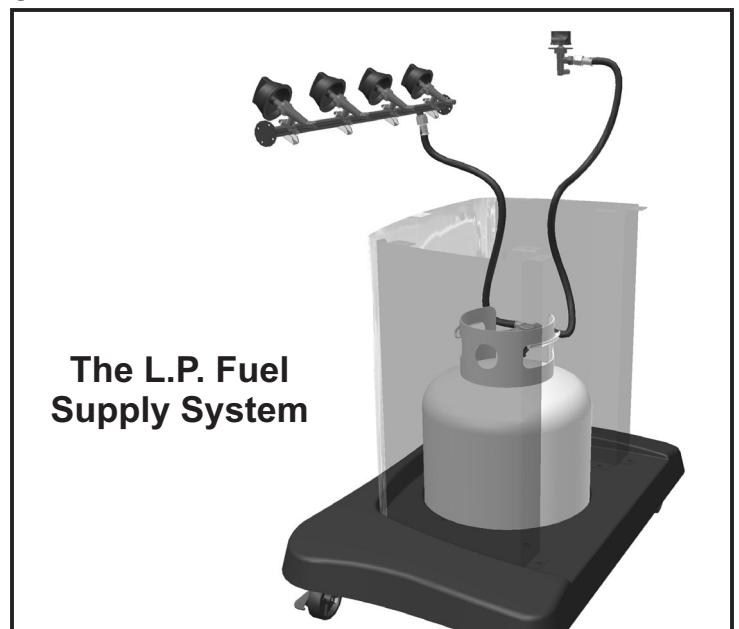

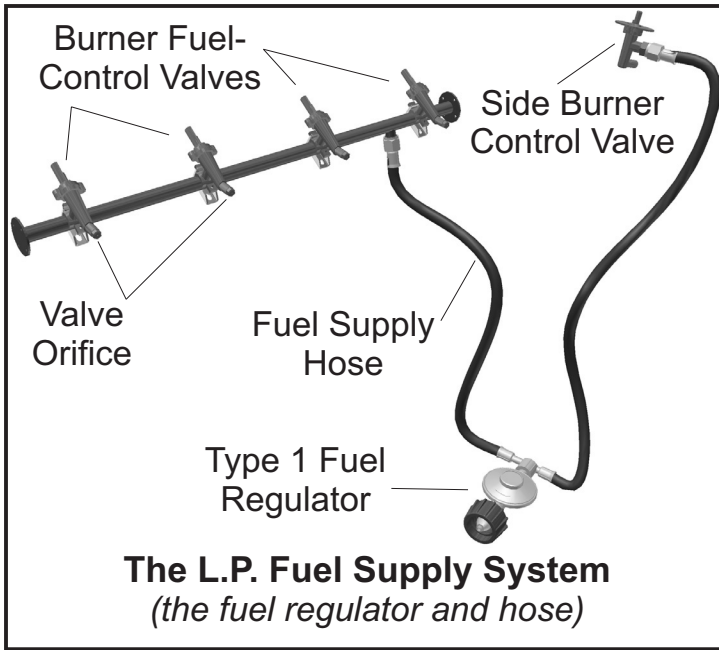

4. The pressure regulator and hose assembly provided is factory set at an outlet pressure of 11 inches water column (.4 lb. per sq. Inch).

WARNING: Any attempt to adjust the regulator is dangerous and could create a situation causing personal injury or property damage. Consult your L.P. gas dealer if you think the regulator is not working properly.

L.P. GAS SUPPLY CYLINDER

L.P. Cylinders can be obtained at the store where you purchased your grill or from an authorized L.P. gas dealer.

FUEL REGULATOR AND HOSES

The fuel regulator supplied is equipped with a Type 1 coupling nut. Do not attempt to connect to any other L.P. cylinder not equipped with a mating Type 1 cylinder valve. This grill is not to be used with any other cylinder connection device.

The fuel regulator and hose assembly with the Type 1 fitting supplied must be used with the appliance. Do not use a hose and regulator assembly other than the one supplied with the grill or a manufacturer's replacement fuel pressure regulator assembly.

The Type 1 connection system has the following features:

1. The system will not allow gas to flow until a positive connection has been made.
2. The system has a thermal element that will shut off the flow of gas between 240°F and 300°F.
3. The system has a flow-limiting device which, when activated, will limit the flow of gas to 10 cubic feet per hour.

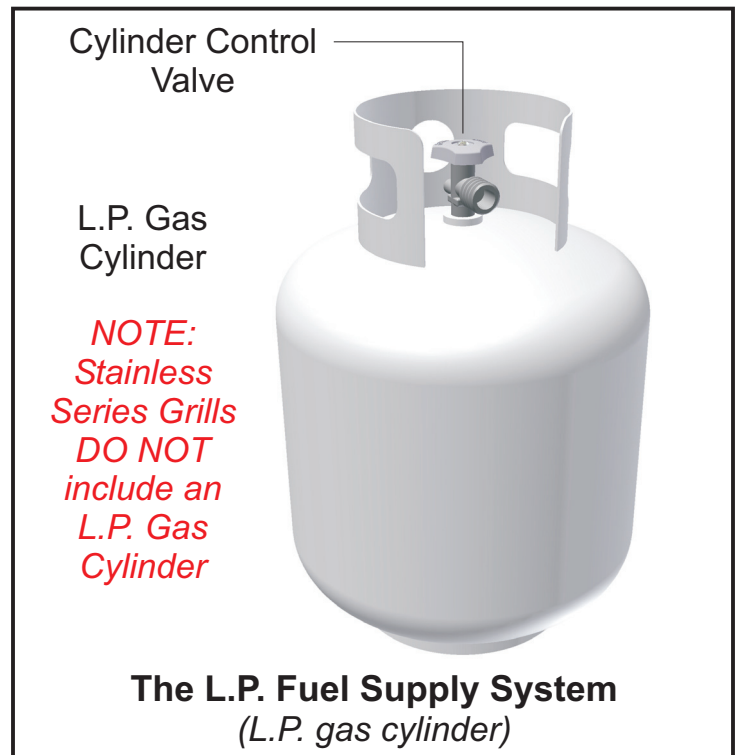

L.P. GAS CYLINDER SPECIFICATIONS

Any L.P. gas-supply cylinder used with this grill must be approximately 12 inches diameter and 18 inches high. The maximum fuel capacity must be 20 pounds of propane. Full-cylinder weight should be approximately 38 pounds (43.7 lbs. Nominal water capacity).

The L.P. cylinder must have a shut-off valve terminating in a Type 1 L.P. gas-cylinder-valve outlet. A Type 1 compatible cylinder with a Type 1 cylinder valve has a positive seating connection that does not permit gas flow until a positive seal has been obtained.

The cylinder must be arranged for vapor withdrawal. It must also include a collar to protect the cylinder valve. A safety-relief device having direct communication with the vapor space of cylinder must be provided. This will expel high-pressure gas if the cylinder is overfilled or overheated.

All L.P. gas cylinders used with this appliance shall be constructed and marked in accordance with the specifications for L.P. gas cylinders of the U.S. Department of Transportation (DOT) or the National Standard of Canada, CAN/CSA-B339, Cylinders, Spheres and Tubes for Transportation of Dangerous Goods; and Commission, as applicable; and shall be provided with a listed overfilling-prevention device. Read labels on the L.P. gas-supply cylinder.

DANGER: Do not insert any foreign objects into the valve outlet. You may damage the back check, A damaged back check can cause a leak, which could result in explosion, fire, severe personal injury or death.

Allow only a qualified L.P. gas dealer to fill or repair an L.P. gas-supply cylinder.

Inform the gas dealer if it is a new or used cylinder to be filled. Caution the gas dealer not to overfill the fuel cylinder.

After filling, have the gas dealer check for leaks and that the relief valve remains free to function.

Have the gas dealer weigh the cylinder after filling to ensure that the cylinder is not overfilled.

DANGER:

a.) Do not store a spare L.P. gas cylinder under or near this appliance.

b.) Never fill the gas cylinder beyond 80 percent full.

c.) If the information in (a.) and (b.) Is not followed exactly, a fire causing serious injury or death may occur.

TRANSPORTING A FULL CYLINDER

WARNING: Handle a full cylinder with care. Gas is under high pressure.

You should transport only one cylinder at a time. Transport the cylinder in an upright and secure manner with the control valve turned off and the POL plug in place.

Do not transport a cylinder in the passenger compartment of a vehicle.

Do not leave cylinder in direct sunlight or in a high-heat area such as a closed car trunk. High-heat areas could cause the relief valve to vent gas.

Use a cylinder cap on the cylinder-valve outlet during transport and when the cylinder is not connected to the grill. Keep cylinder valve closed when not in use.

Take These Instructions to the L.P. Gas Dealer

When using a cylinder exchange, be sure the exchanged cylinder is a Type 1 cylinder; a 510 POL cylinder will not fit a Type 1 regulator.

FILLING AND PURGING TYPE 1 L.P. GAS CYLINDERS

DANGER: Purging and filling of L.P. gas cylinders must be performed by personnel who have been thoroughly trained in accepted L.P. gas industry procedures. Failure to follow this instruction may result in explosion, fire, severe personal injury or death.

IMPORTANT: Purge new cylinders before filling. This tank is easily filled with a standard CGA 510 POL filling connection.

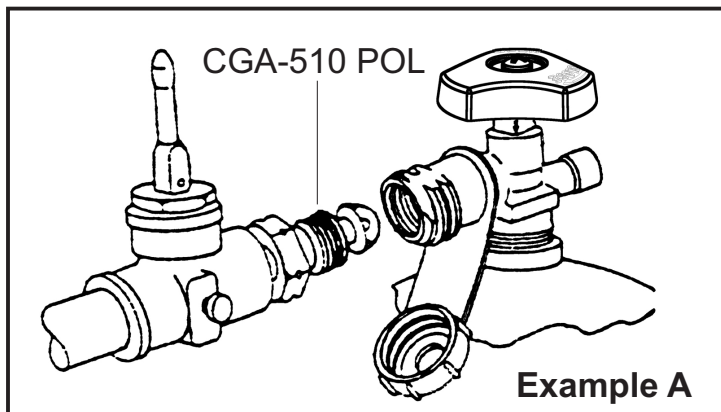

Filling a Type 1 Cylinder Valve

*Example A: shows a CGA-510 POL fitting.
Example B: shows using a Type 1 POL fitting.*

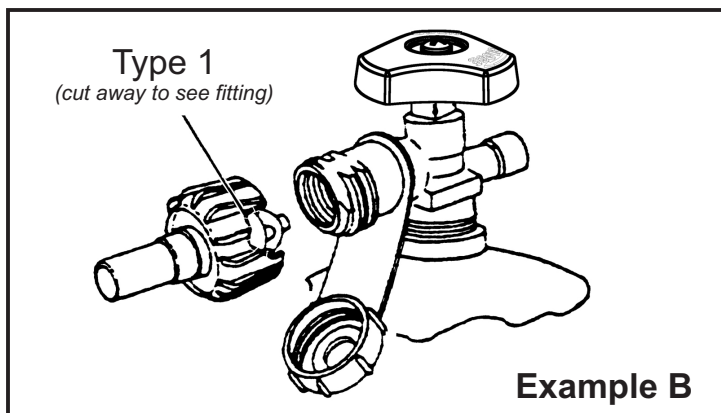

The L.P. gas cylinder has a Type 1 cylinder valve with a back-check module in its outlet that will not permit gas to flow until an evacuation device is installed. To purge the L.P. gas cylinder, the back-check module must be opened with an evacuation device.

PURGING AND EVACUATION DEVICES FOR L.P. GAS CYLINDER WITH TYPE 1 CYLINDER VALVES

A. Hose-end valve with a bleed port: Purging can be accomplished using a hose-end valve containing a bleed port, which also allows for evacuation without the use of an adapter.

B. Hose-end valve without a bleed port: When a hose-end valve does not have a bleed port, a separate device must be used for evacuation.

C. Purging using a Type 1 connection: L.P. gas cylinder evacuation can be accomplished during each purging by using a Type 1 connection. The Type 1 valve outlet has 1-5/16" external ACME right-hand thread that will accept this connection.

CAUTION: After purging or filling an L.P. gas cylinder, do not insert a POL plug into the valve outlet. Insertion of this plug will prevent the back-check from closing. Use ONLY the provided cap and strap attached to the outlet. Close the cylinder valve knob before returning the cylinder to the customer.

For proper purging procedures in the USA, refer to: Safety Bulletin NPGA # 133, "Purging L.P. Gas Cylinders," and Safety Bulletin NPGA #130, "Recommended Procedures for Filling Cylinders."

DANGER: Do not fill an L.P. gas cylinder beyond 80% full. If this information is not followed exactly, a fire causing serious injury or death may occur.

Stainless Series Gas Grill

Assembly Instructions Chapter 2

Tools needed to assemble grill:

- 10mm open-end wrench
- phillips-head screwdriver

(tools not included)



Getting Started

1. Please follow the steps in the order that they are presented.
2. Assemble the grill where you plan to use it.
3. You may want to place an old towel or cloth at the assembly site to prevent nuts and bolts from becoming lost.
4. For each step, loosely tighten all the fasteners before tightening them completely.
5. Have a friend help. An assistant can make the assembly easier by holding the parts in place while you fasten the nuts and bolts.
6. To be ready to barbecue immediately, have the L.P. gas cylinder filled by an authorized L.P. dealer or cylinder exchange center.

Unpacking the Grill Parts

1. Remove and set aside all inner boxes and parts from the master carton.
2. Remove and set aside all wrapping paper, zip ties, and additional protective packaging from the parts.
3. Do not destroy carton or packing until your grill is completely assembled and operating to your satisfaction.
4. For ease and safety, lock the casters during assembly.

Consumer:

Your grill is packaged with a merchandiser point-of-purchase label. To remove the label, unscrew the igniter button, remove and discard the label, then re-attach the igniter button.

Retailer/Merchandiser:

Do Not remove the point-of-purchase label. Make sure it is hanging properly for display in the store.

Assembly Step 1 - Identifying the Grill Parts

Locate these parts:

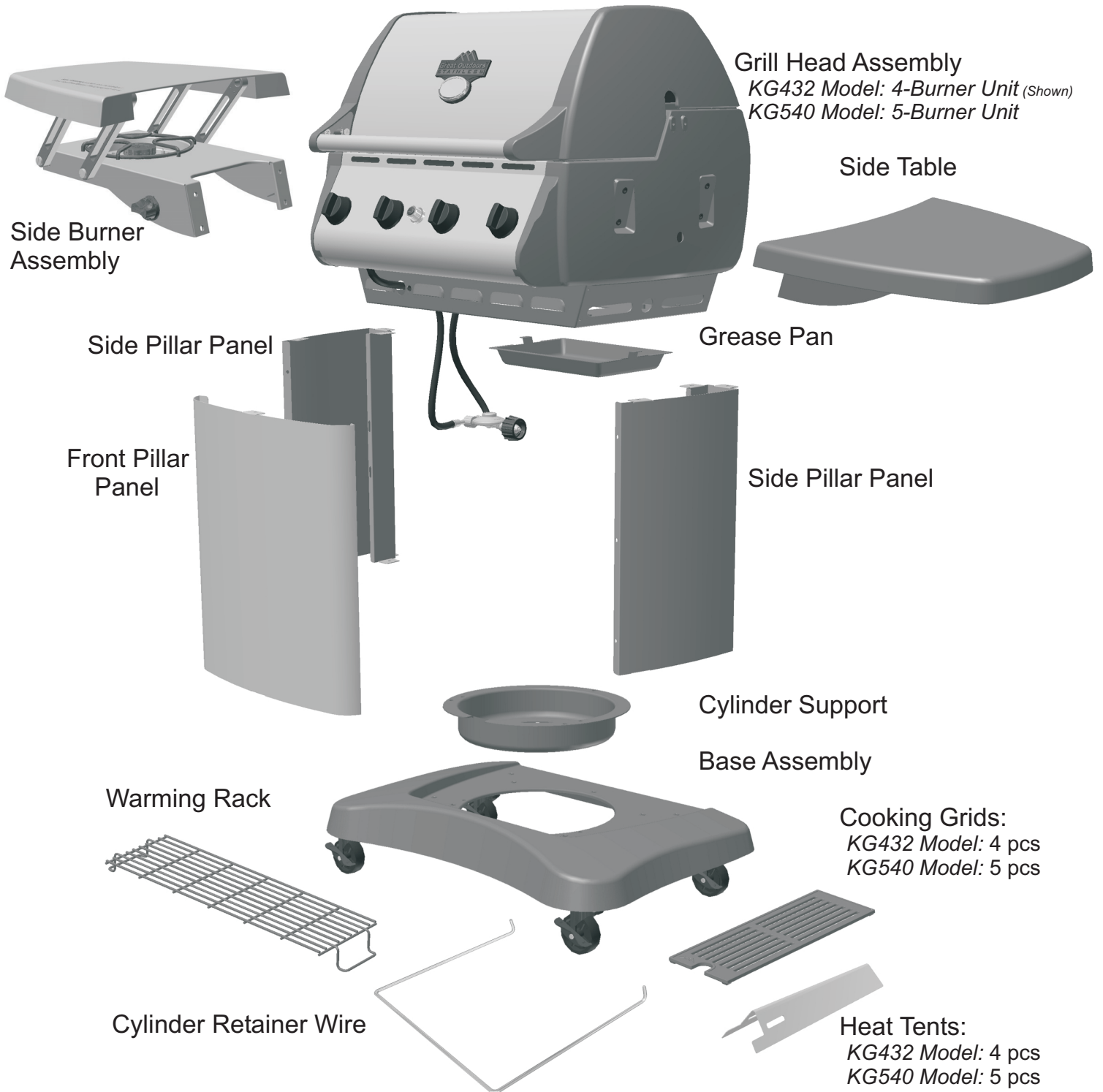

Not Pictured:
master hardware pack
(consisting of 1 each of A,B,C,D,E packs)

L.P. Tank Not Included

Assembly Step 2 - Assemble the Pillar Panels

Tools Needed:

Phillips head
screwdriver



10mm
wrench

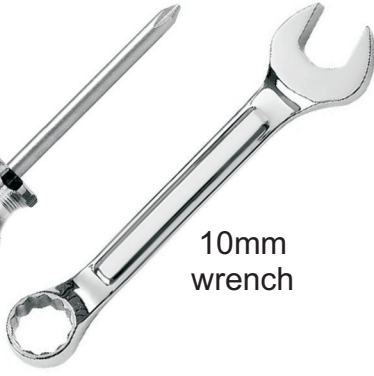

USE HARDWARE PACK A :

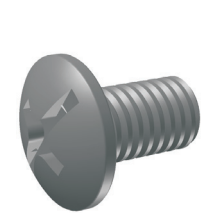

M6x1x10mm
Bolt (6)

Lock
Washer (6)



Flat
Washer (6)

M6x1
Nut (6)

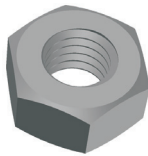

LOCATE THESE PARTS:

Front Pillar
Panel (1)

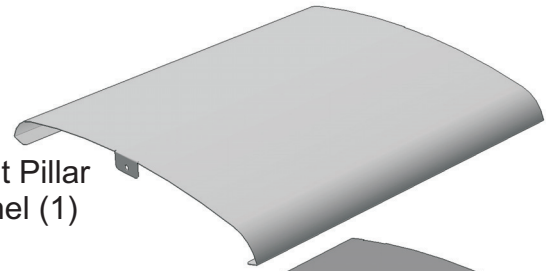

Side Pillar
Panel (2)

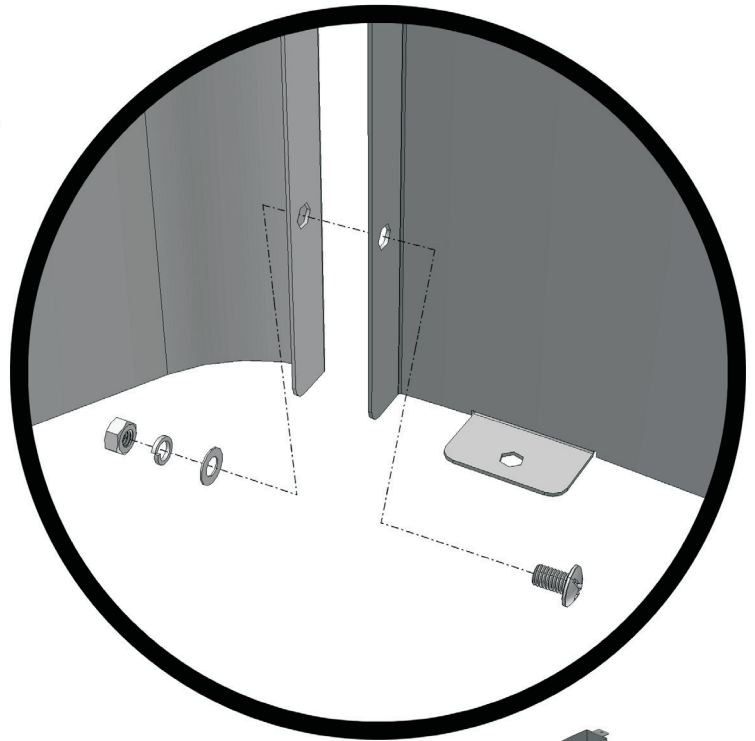
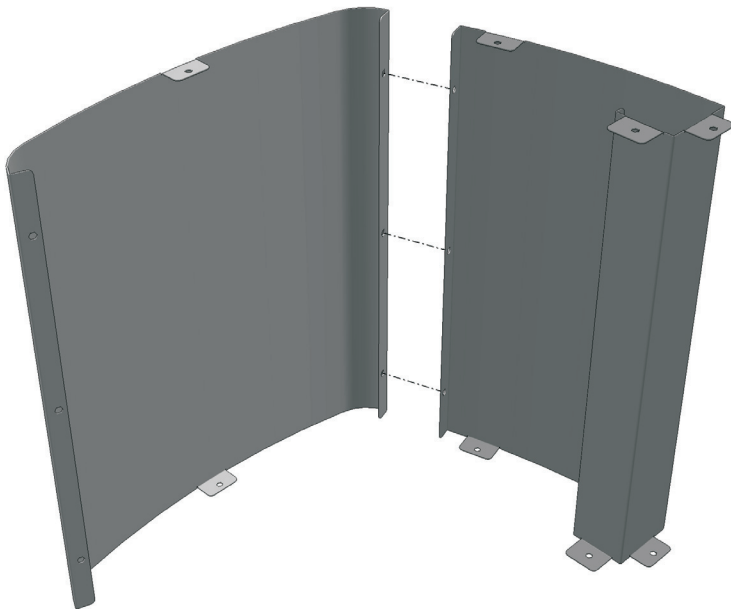
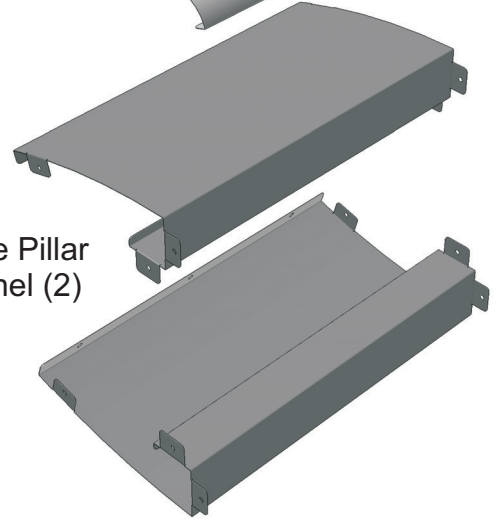

1. Align one edge of the Front Pillar Panel with the corresponding edge of one Side Pillar Panel as shown.
2. For each mounting hole, insert a bolt and thread on a washer, lock washer, and nut as shown.
NOTE: For easier assembly, first loosely insert ALL of the nuts and bolts before tightening them.

3. Firmly tighten the nuts and bolts.
4. Repeat steps 1 through 3 for the second Side Pillar Panel.

Assembled Pillar:

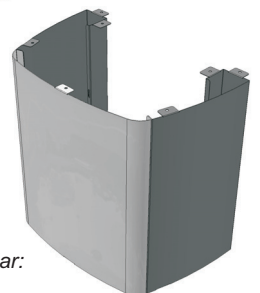

Assembly Step 3 - Assemble the Pillar to the Base

Tools Needed:



Phillips head screwdriver

LOCATE THESE PARTS:



Cylinder Support

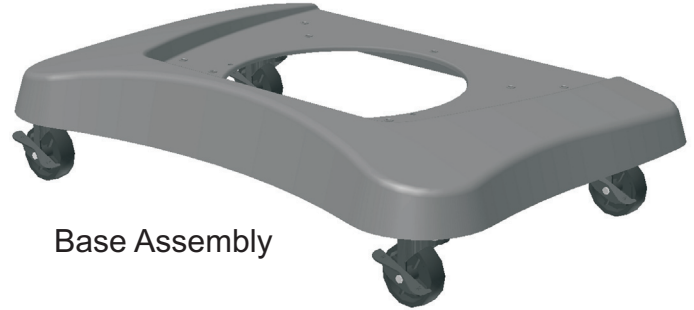

Base Assembly

USE HARDWARE PACK B :

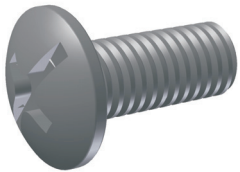

M6x16mm Bolt (10)



Flat Washer (10)



Lock Washer (10)

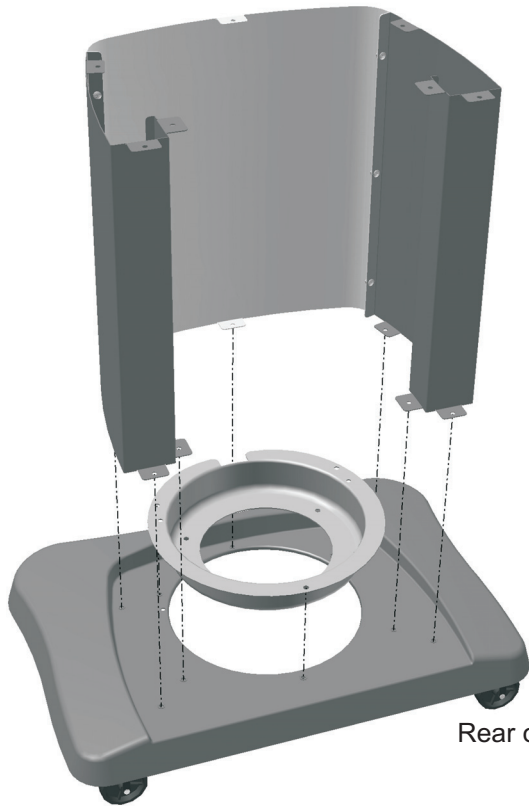

Rear of Grill Assembly

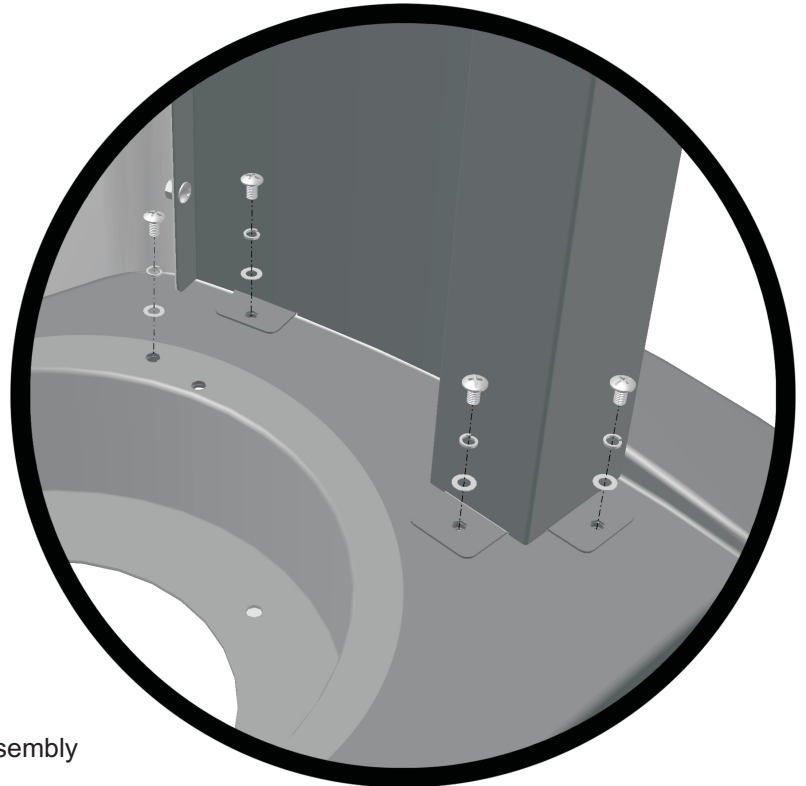

1. Set the Cylinder Support into the hole in the Base as shown with the notch toward the front.
2. Set the assembled Pillar panels onto the Base Assembly as shown.
3. For each pre-threaded mounting hole, insert a bolt, washer, and lock washer for both the pillar and the cylinder support.
4. Firmly tighten the bolts.

NOTE: For easier assembly, first loosely insert ALL of the screws before tightening them.

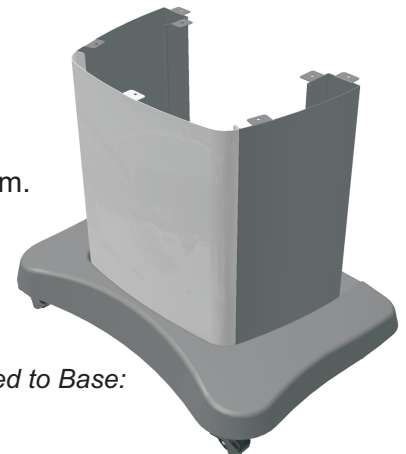

Pillar assembled to Base:

Assembly Step 4 - Attach the Grill Head to the Pillar

Tools Needed:



Phillips head screwdriver

USE HARDWARE PACK C :

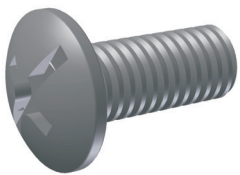

M6x16mm Bolt (7)



Lock Washer (7)



Flat Washer (7)

LOCATE THESE PARTS:



Grill Head Assembly

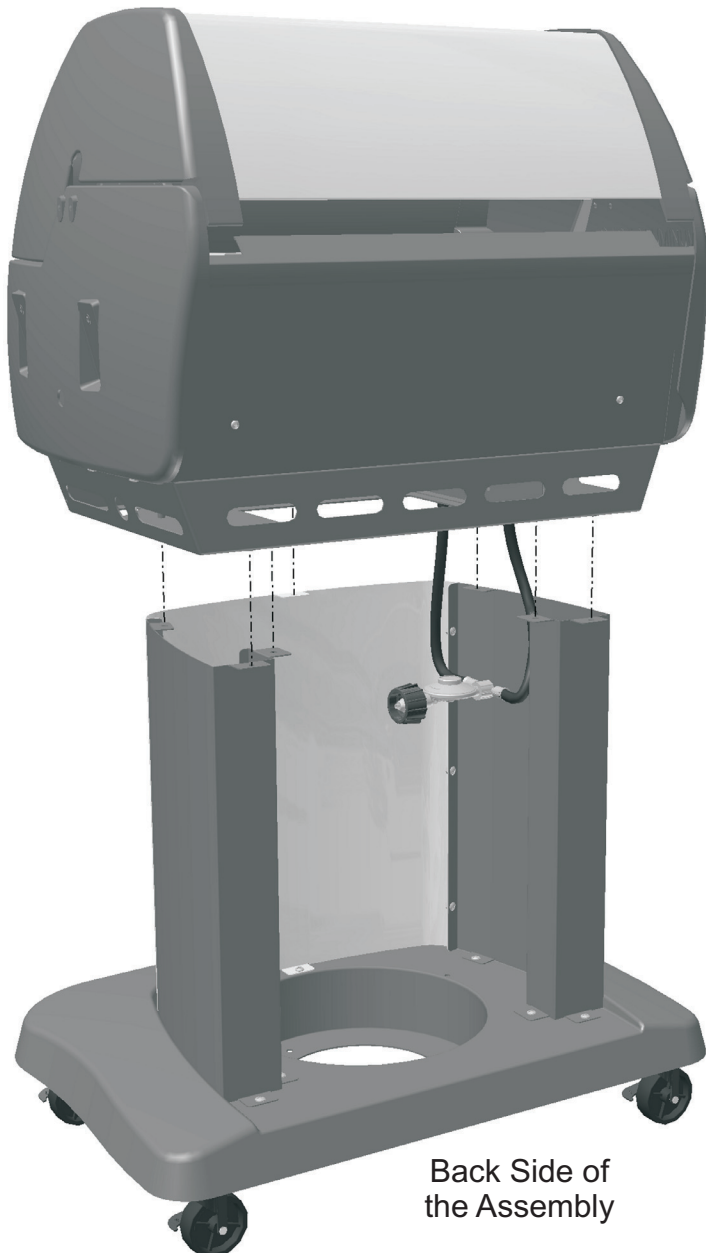

Back Side of the Assembly

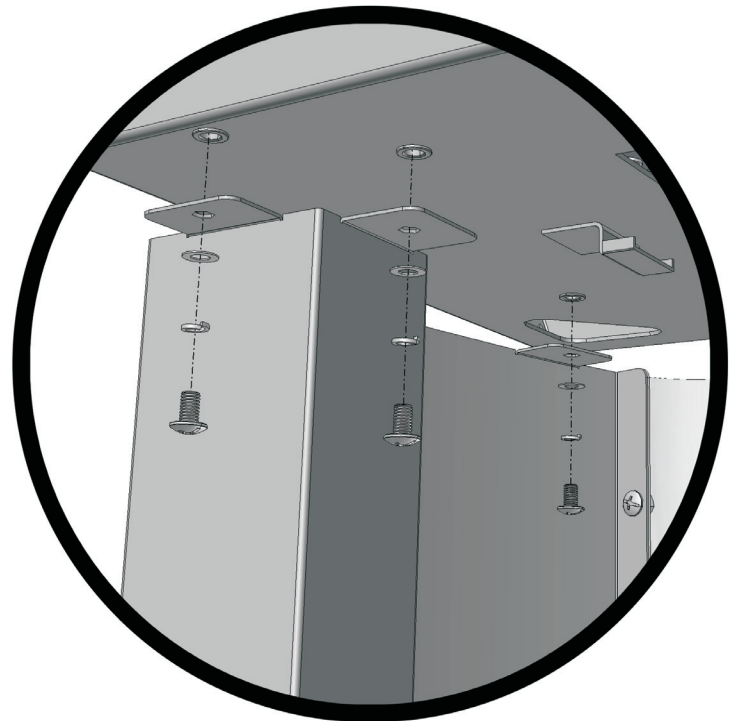

1. Set the Grill Head Assembly onto the top of the assembled Pillar and Base as shown. Ensure that the hose and regulator hanging from the bottom of the Grill Head are on the inside of the Pillar.
2. For each pre-threaded mounting hole, loosely insert a bolt, washer, and lock washer. To make assembly easier, start with the center mounting hole of the front pillar panel and work around to the sides.
3. After all of the fasteners have been loosely placed, firmly tighten the bolts.

Assembly Step 5 - Attach the Side Tables

Tools Needed:



Phillips head screwdriver

USE HARDWARE PACK D :

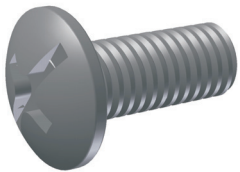

M6x16mm Bolt (8)



Lock Washer (8)



Flat Washer (8)

LOCATE THESE PARTS:

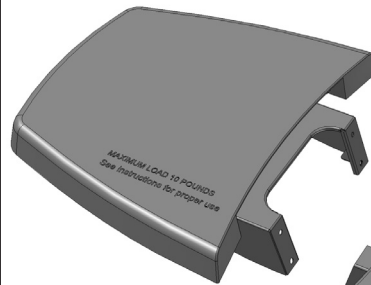

Side Burner Table Assembly

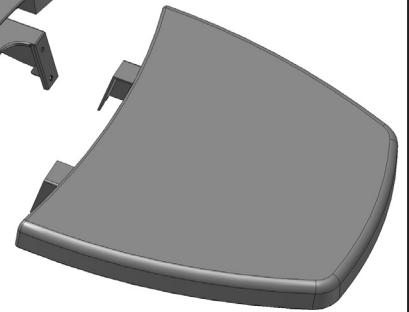

Side Table

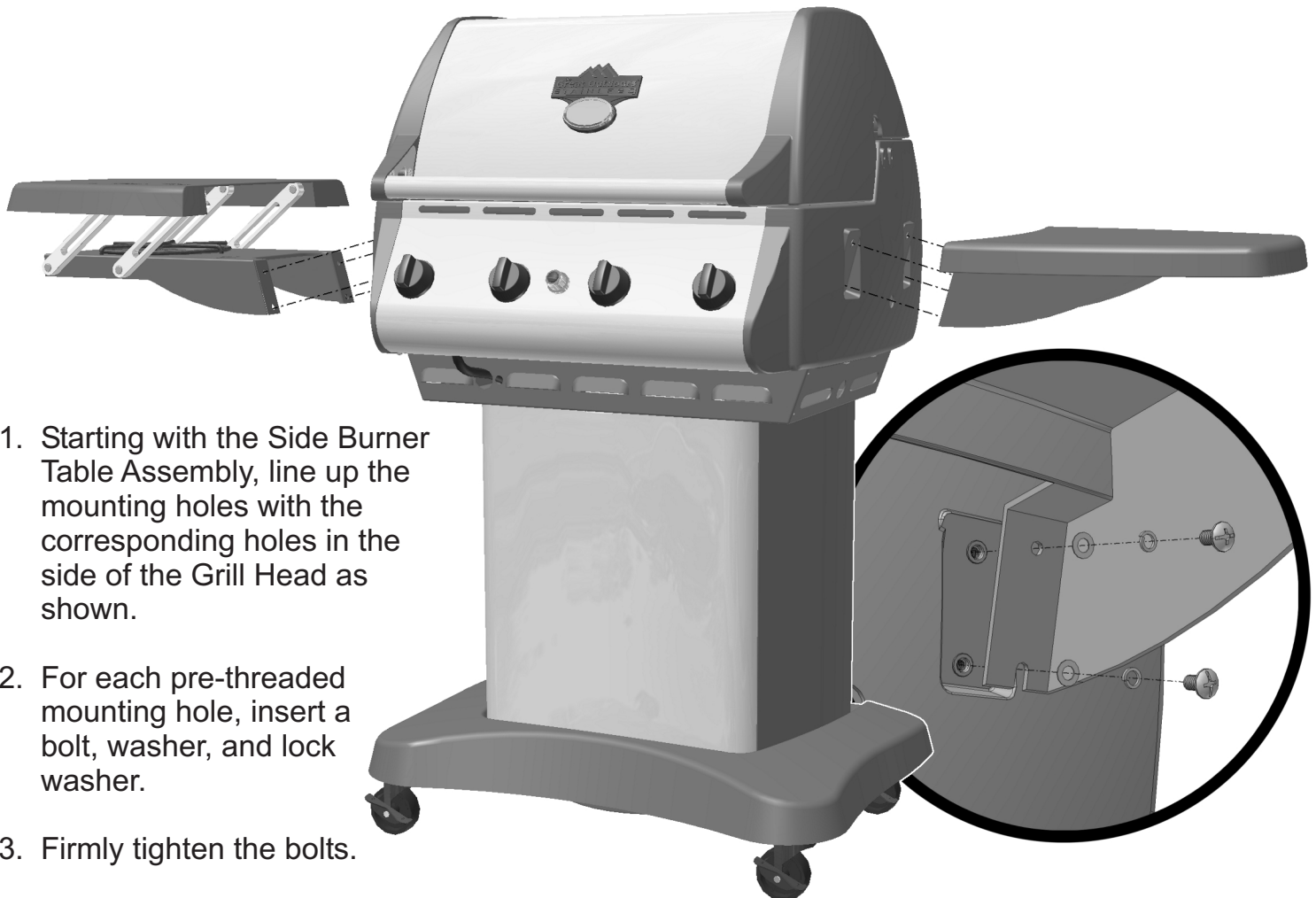

1. Starting with the Side Burner Table Assembly, line up the mounting holes with the corresponding holes in the side of the Grill Head as shown.
2. For each pre-threaded mounting hole, insert a bolt, washer, and lock washer.
3. Firmly tighten the bolts.
4. Repeat steps 1 through 3 for the Right Side Table.

Assembly Step 6 - Mount the Side Burner Knob

Tools Needed:



Phillips head screwdriver

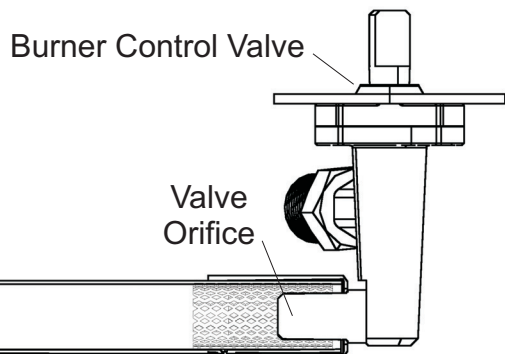
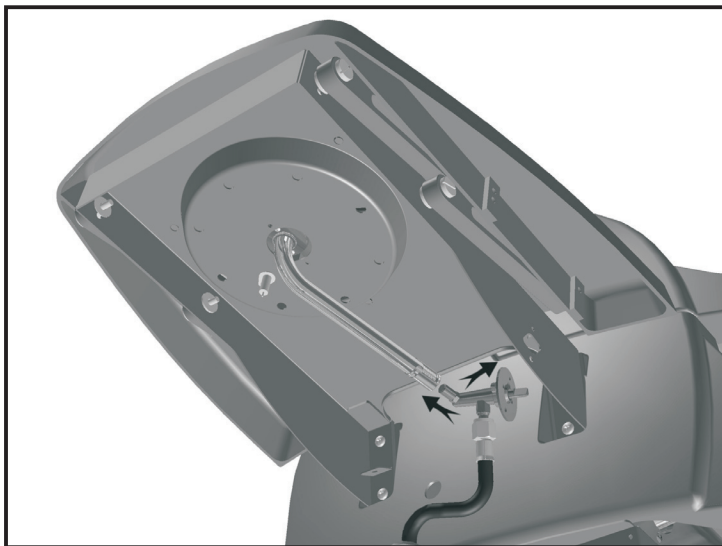
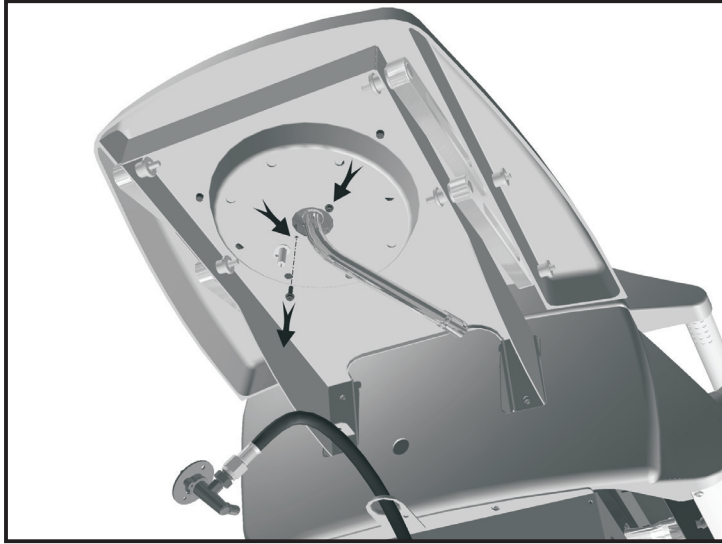

USE HARDWARE PACK E :

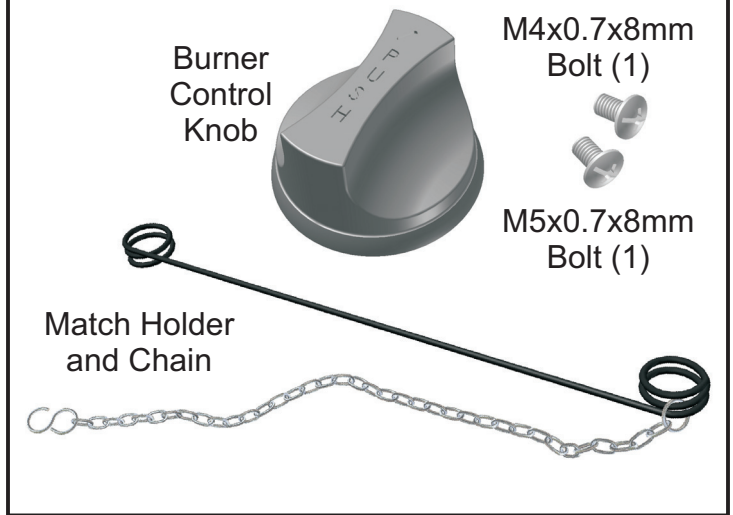

1. Working underneath the Side Burner Assembly, locate and remove the two bolts that are holding the brass burner to the side table. This will allow the burner tube to hang and move freely.
2. Locate the burner control valve attached to the end of the gas hose hanging from the side of the Grill Head Assembly.
3. Insert the orifice of the control valve into the end of the burner tube.
4. Route the control valve stem through the mounting hole in the side table.
5. Re-insert and securely tighten the burner mounting bolts that were removed in step 1 above.

IMPORTANT: The valve orifice must be seated inside the burner tube for safe operation. An improperly seated valve-to-burner tube connection may result in an external fire causing property damage or serious personal injury.

Assembly Step 6 - Continued

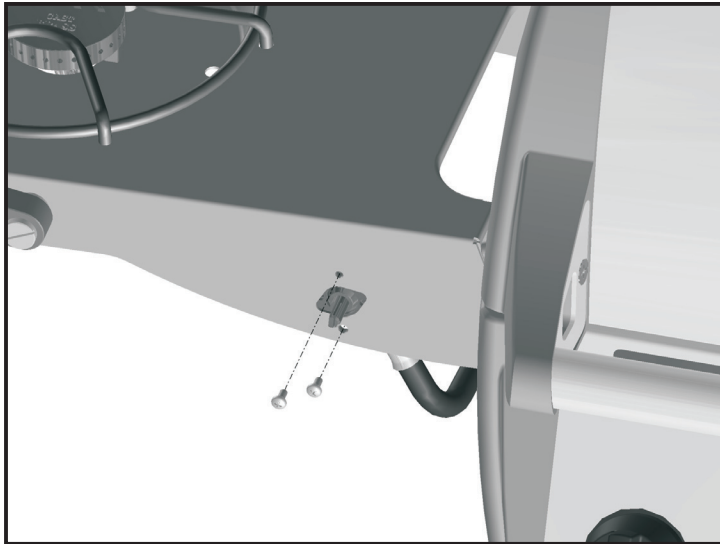

6. From the front side of the side table, insert and tighten the bolts from hardware pack E to the control valve as shown. There are 2 different sized bolts to ensure that the valve is properly oriented.

7. Press the knob onto the control valve stem as shown. Make sure the keyed shaft is properly seated - do not force the knob into place.

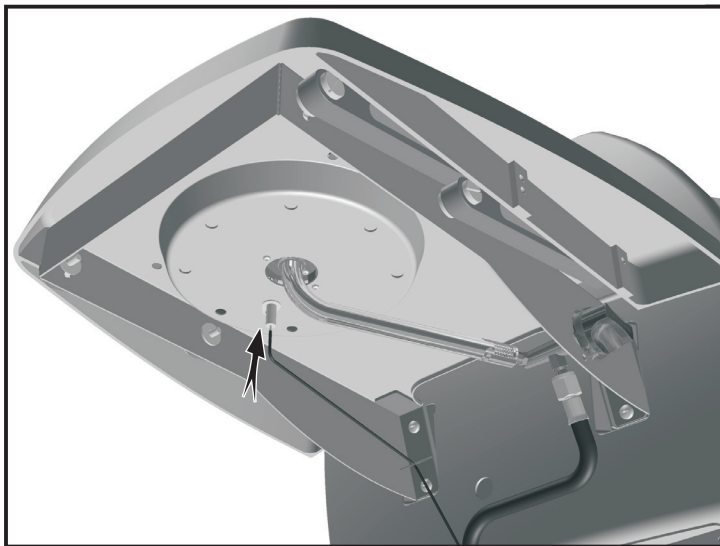
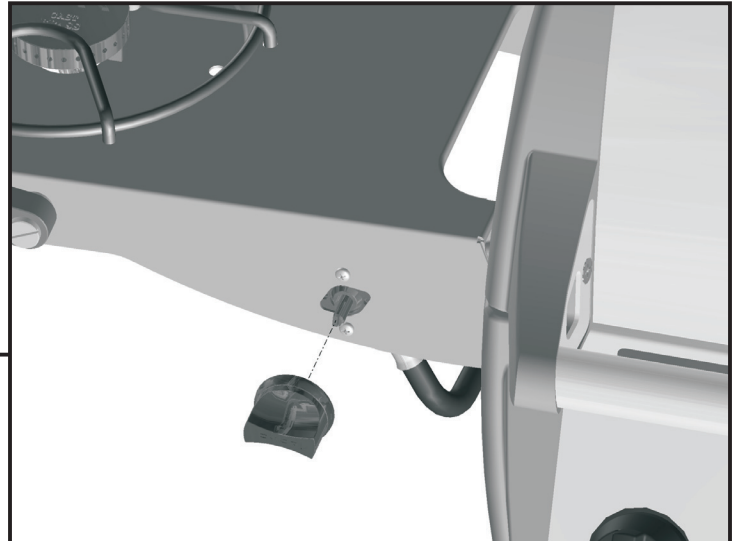

8. Find the single loose black igniter wire under the Grill Head Assembly, near where the side burner hose is ran through the collar. Run the wire up through the mounting tab and connect the end to the side burner igniter electrode.

9. Attach the Match Holder Chain to the same tab by crimping the s-hook end of the chain through the wire hole. The Match Holder is used to hold a match for lighting the burner inside the grill tub. (Optional match-lighting method - see "Lighting Instructions" on pages 23-24.)

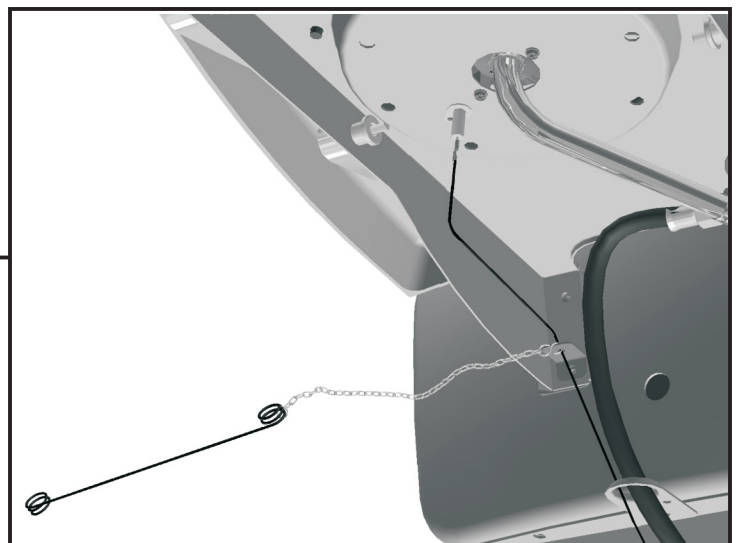

Assembly Step 7 - Assemble Cooking Grids

LOCATE THESE PARTS:

Heat Tents
(KG432 model: 4 pcs)
(KG540 model: 5 pcs)

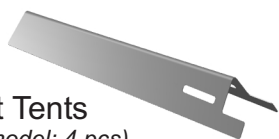

Cooking Grids
(KG432 model: 4 pcs)
(KG540 model: 5 pcs)

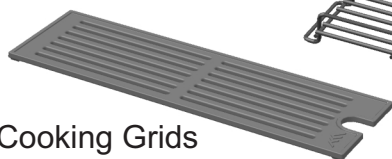

Warming Rack

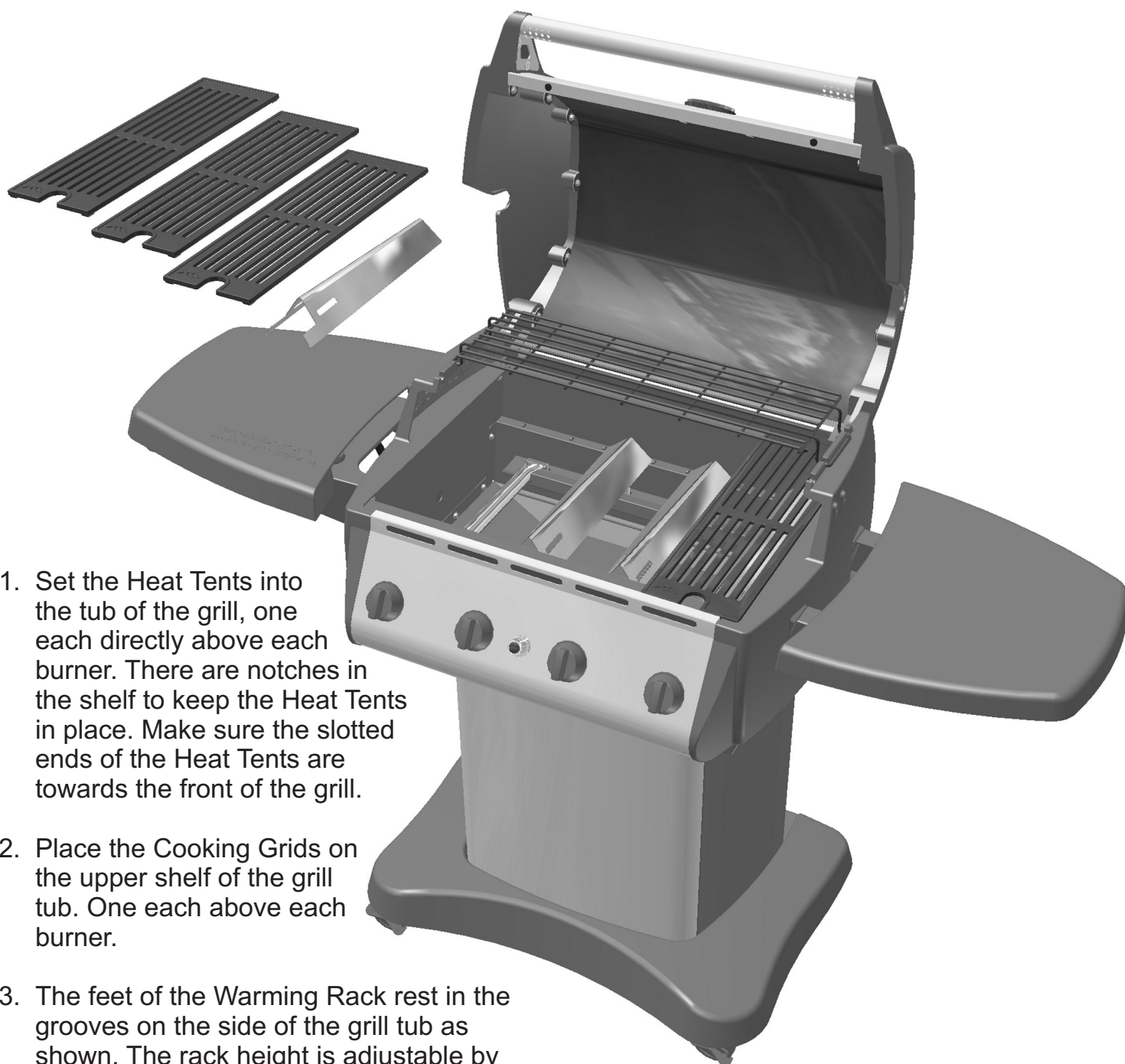
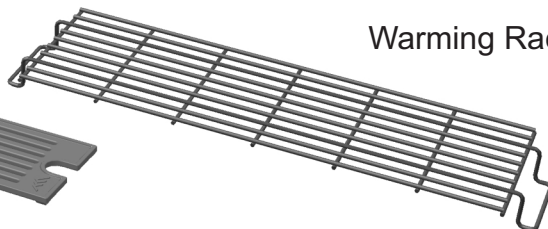

1. Set the Heat Tents into the tub of the grill, one each directly above each burner. There are notches in the shelf to keep the Heat Tents in place. Make sure the slotted ends of the Heat Tents are towards the front of the grill.
2. Place the Cooking Grids on the upper shelf of the grill tub. One each above each burner.
3. The feet of the Warming Rack rest in the grooves on the side of the grill tub as shown. The rack height is adjustable by turning it upside down.

Assembly Step 8 - Grease Pan and L.P. Tank

LOCATE THESE PARTS:

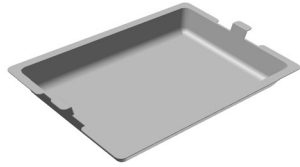

Grease Pan

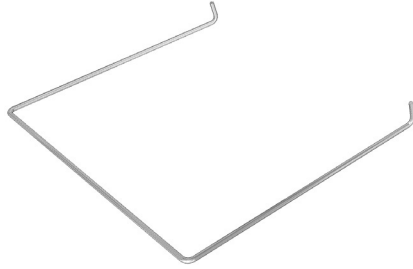

Cylinder Retainer
Wire



L.P. Gas
Cylinder
(filled)

NOT
INCLUDED

1. Place the Grease Pan underneath the Grill Tub from the back side as shown. There are brackets mounted to the underneath side of the tub to hold the Grease Pan in place.

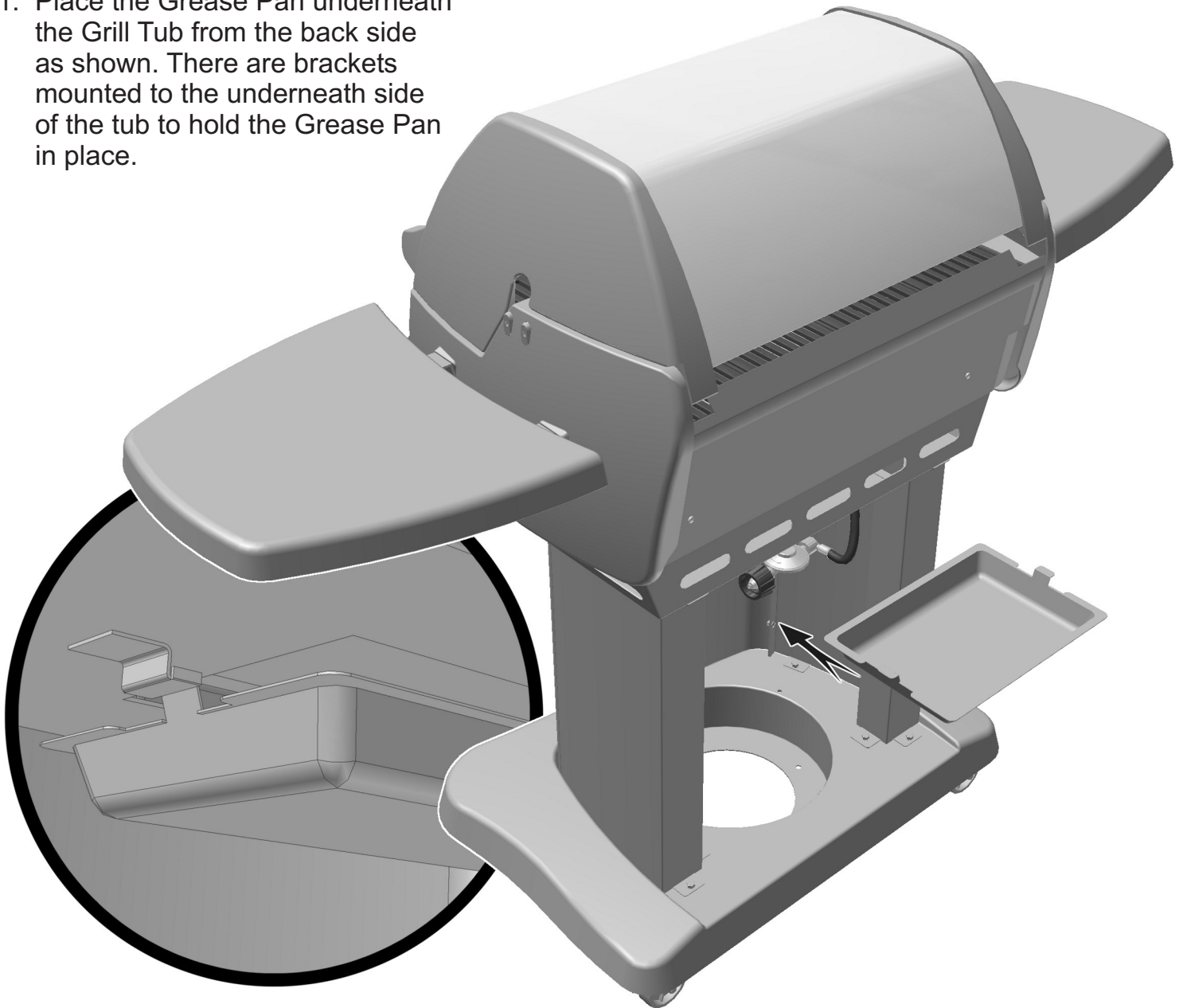

Assembly Step 8 - Continued

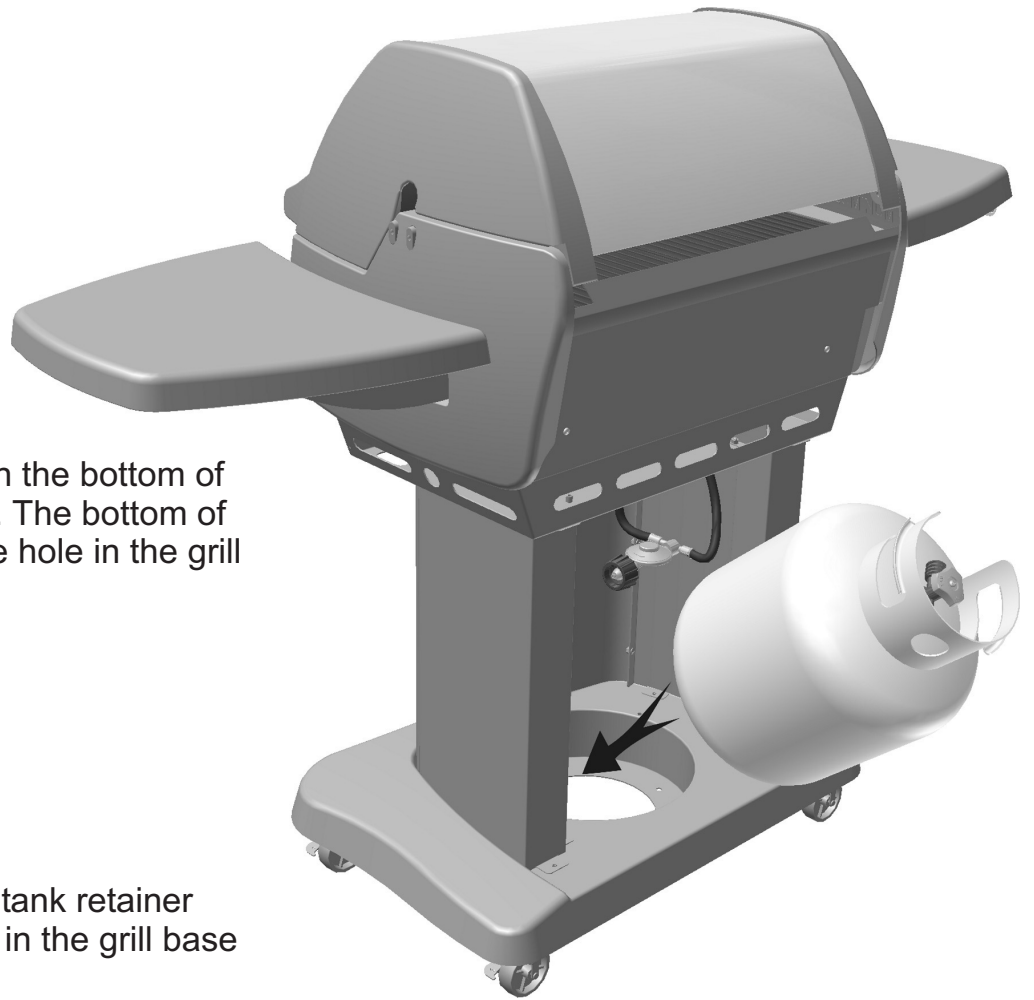

2. Set the L.P. Gas Cylinder in the bottom of the grill from the back side. The bottom of the cylinder rests inside the hole in the grill base.

3. Insert the bent ends of the tank retainer wire into the retainer holes in the grill base as shown.

4. Lift the retainer wire up around the gas cylinder and lock it in place.

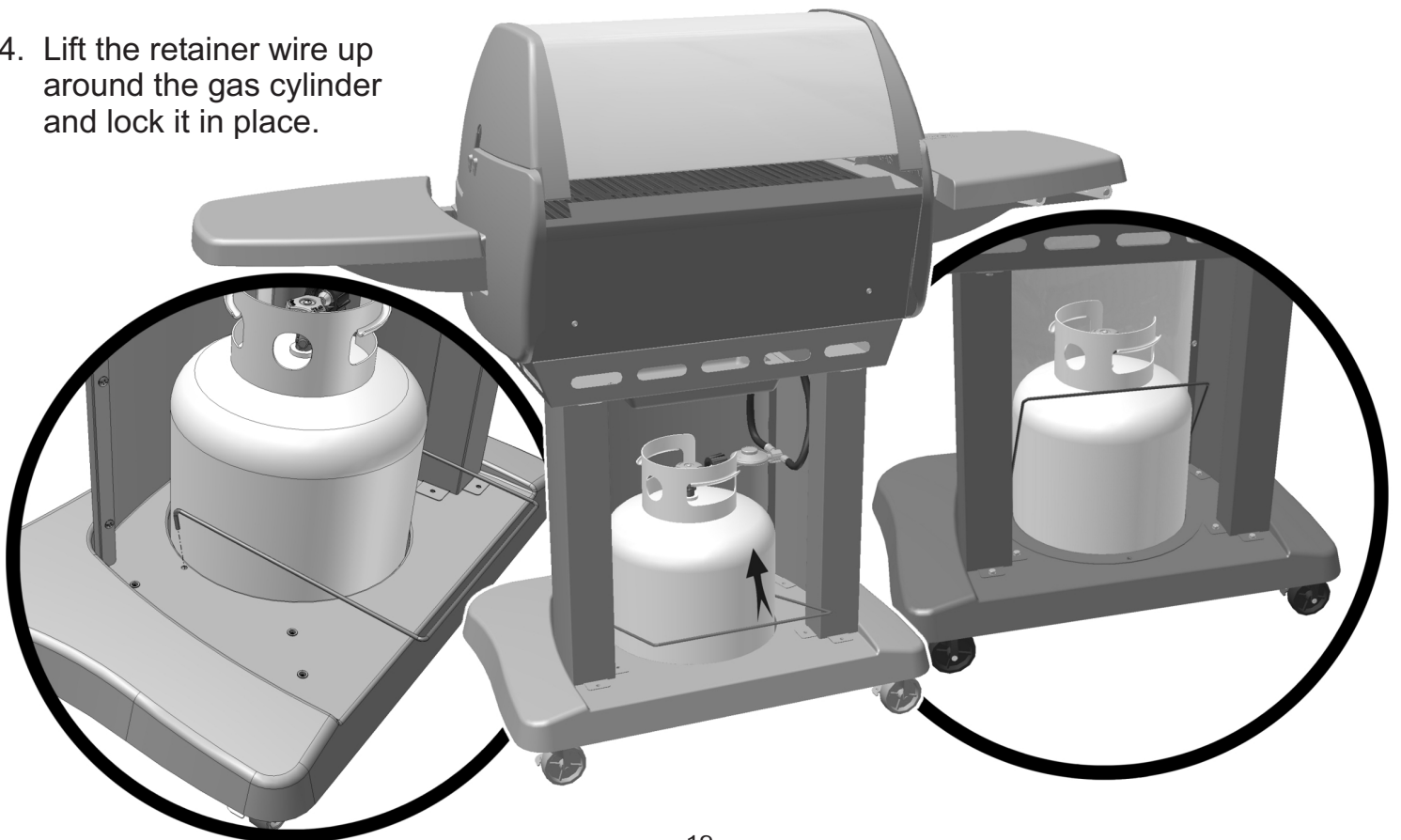

Connecting the L.P. Gas Cylinder

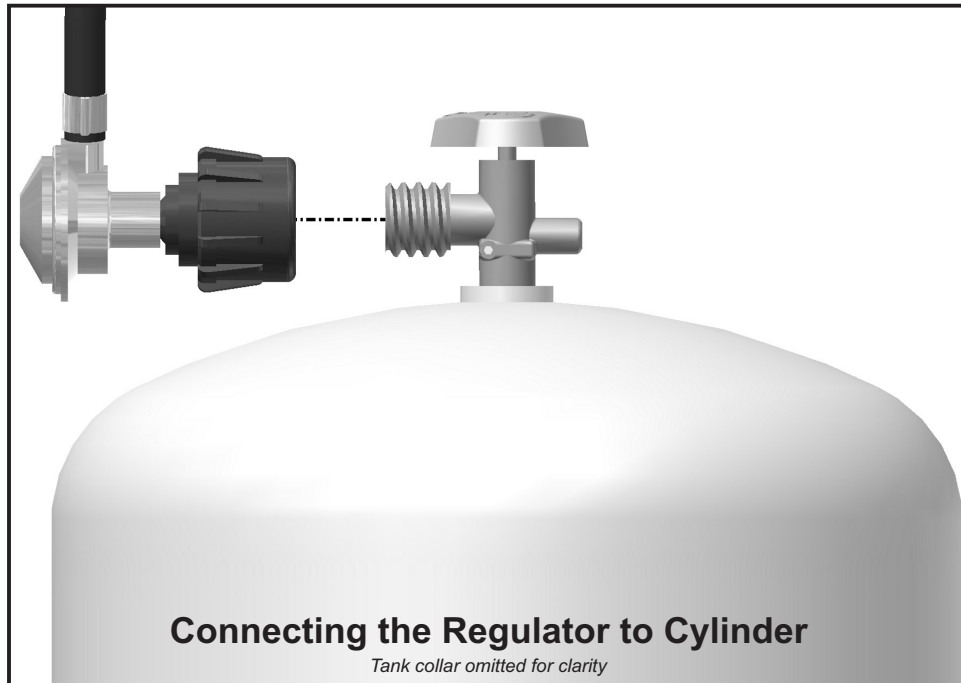

1. The top knob on the supply cylinder must be closed. See that the top cylinder knob is turned clockwise to a full stop.

2. Check that all the grill burner knobs are turned off.

3. Remove the protective caps from the cylinder valve and coupling nut, if present.

4. Hold the regulator in one hand and insert the nipple into the valve outlet. Be sure the nipple is centered in the valve outlet. The coupling nut connects to the large outside threads on the valve outlet. Use care not to cross thread the connection.

5. Hand tighten the coupling nut clockwise until it comes to a full stop. Tighten by hand only. Do not use tools.

6. **CAUTION:** In the connection process, the grill side of the connection will seal on the back check in the valve, resulting in a slight resistance. The connection requires about one-half to three-quarters additional turn to complete the connection.

NOTE: If you cannot complete the final connection, disconnect the regulator and repeat steps 4 through 6. If you are still unable to complete the connection, do not use this valve and regulator.

7. Make sure the hose has no kinks or sharp bends and clears any areas that will become hot during use. Never put strain on the hose where it joins a fitting. The rubber fuel supply hose must not touch the bottom grill casting during use.

8. Before lighting grill, check all connections for leaks using a mild soapy-water solution.

9. Make sure the grease pan is in place before operating. If the grease pan is not in place, hot grease and debris will fall on the gas cylinder and may cause damage to the fuel supply system.

Natural Gas Grills - Connecting to Natural Gas

(for specially equipped natural gas grills only)

DANGER: EXPLOSIVE AND FLAMMABLE!
If the appliance is for connection to natural gas, the gas connections should be made by a qualified installer or a licensed plumber. The gas-supply line must not be installed by the consumer.

The valve-orifices and fuel supply hose system necessary for use with natural gas is different than the system required for L.P. gas. Modification to the burner valve/orifices allow the use of natural gas. An L.P. cylinder is not needed.

WARNING: Do not use liquid propane (L.P.) gas in an appliance designed for natural gas. Use only natural gas in an appliance designed for natural gas.

INSTALLATION FOR NATURAL GAS

The maximum inlet supply pressure is 11.0" w.c. for propane gas and 7.0" w.c. for natural gas.

The specified supply pressure is 11.0" w.c. for propane gas and 7.0" w.c. for natural gas.

The piping system should be installed by a qualified service technician in accordance with the National Fuel Gas Code (NFPA 54/ANSI Z223.1) in the U.S.A., including:

1. The appliance and its individual shut-off valve must be disconnected from the gas-supply piping system during any pressure testing of that system at test pressures in excess of 1/2 psi (3.5 kPa).
2. The appliance must be isolated from the gas-supply piping system by closing its individual manual shut-off valve during any pressure testing of the gas supply piping system at test pressures equal to or less than 1/2 psi (3.5 kPa).

A quick-connect coupling sleeve with 3/8" female end is provided. Install the connector socket at the pipe end, after the shut-off valve. This must be installed where the grill will be in use.

It is important to observe the safety guidelines for choosing a safe location. The gas supply must be shut off prior to installation of the quick connector socket. Use only a matching factory authorized quick-connect plug with the quick-connect socket.

Natural-gas units are equipped with a 12-footlong quick-connect fuel hose in place of the shorter hose/regulator attached to the burner valve.

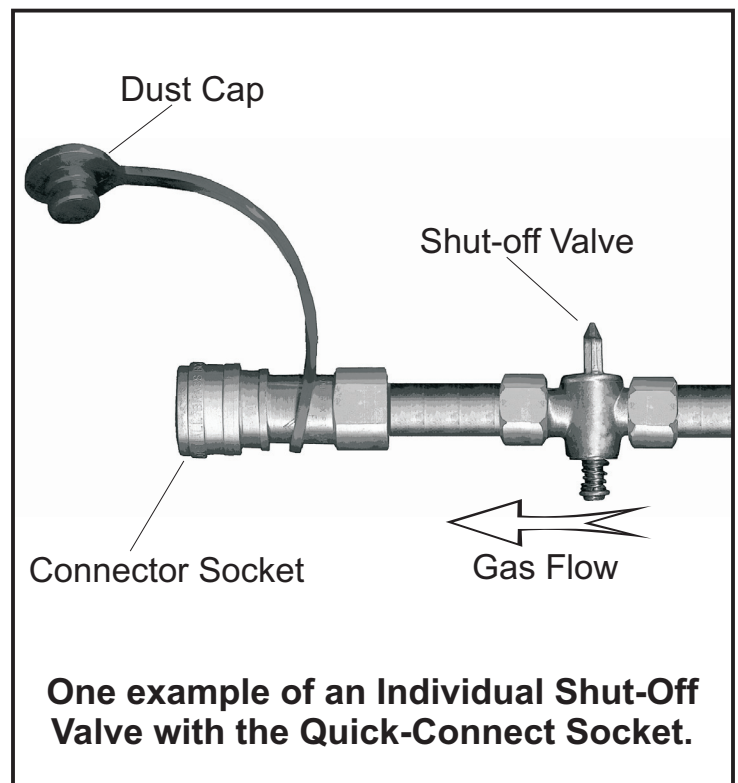

Prior to inserting, turn on gas supply and test all connections with an ammonia-free soap and water solution. Apply this solution to the stem of the shut-off valve and opening of the socket to detect leaks. (See Leak Testing Natural Gas Connections on the following page).

Natural Gas Grills - Connecting to Natural Gas

(for specially equipped natural gas grills only)

OPERATING THE QUICK-CONNECT

Follow all directions on tags attached to hose.

1. To connect the fuel-supply hose to the fuel supply, the shut-off valve must be closed.

2. Remove the dust cap from the connector socket by sliding the connector sleeve back to release the plug. Remove the dust cap from the plug.

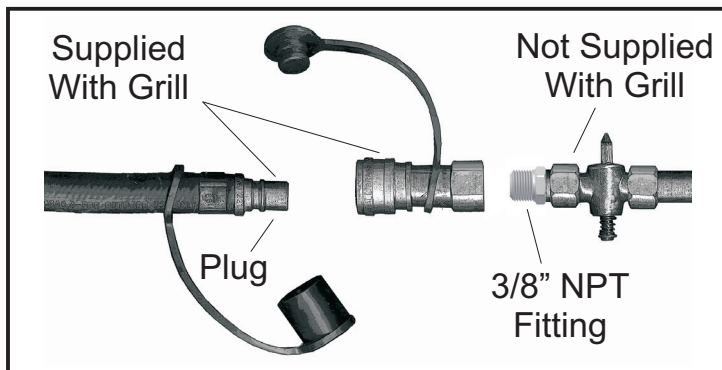

3. Position the plug end of the fuel supply hose into the sleeve opening.

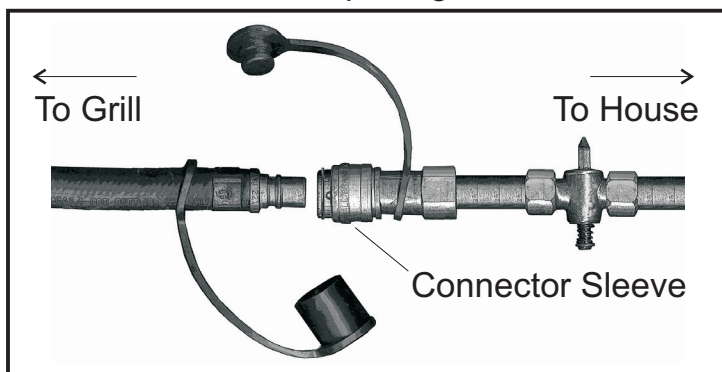

4. Slide the connector sleeve back, firmly push the fitting into the connector.

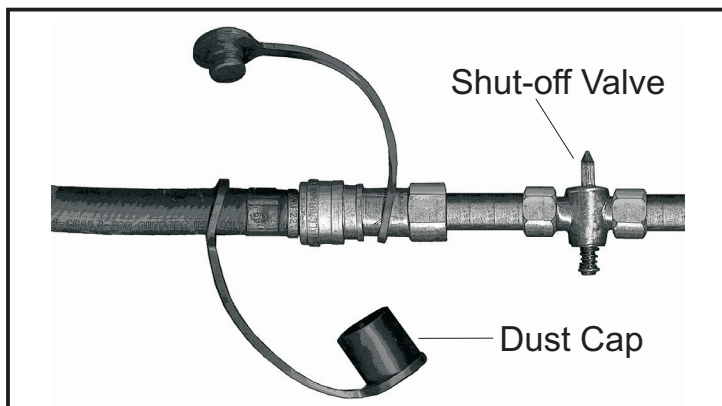

5. Push the plug into the connector until the sleeve snaps forward to lock the fitting in place. Turn on the shut-off valve. The flow of gas to the appliance will be restricted if the plug is not connected properly.

6. Test for gas leaks using an ammonia-free soap and water solution.

TO DISCONNECT THE FUEL SUPPLY

1. Pull connector sleeve back and pull plug out of socket. This will automatically shut off gas to the appliance.

2. Close the shut-off valve and install the dust caps on the socket and plug. Always turn off the fuel supply at the shut-off valve when the grill is not in use.

LEAK TEST CONNECTIONS

Test all the fuel supply connections using an ammonia-free soap and water solution equally mixed. Never use fire to test for leaks.

1. Turn on the gas shut-off valve.

2. Coat all connections of the fuel supply system, especially at the quick-connect.

3. Watch for bubbles to indicate a leak.

4. If there is a leak, shut off the gas supply and re-connect the hose to the socket. Re-test for leaks.

Do not use the grill if a leak is detected that cannot be corrected in this manner or if the hose and connections become damaged. Replace damaged components with only factory authorized parts.

Do not strain or kink the fuel-supply hose. See that the hose is kept clear of surfaces that become hot during use.

Stainless Series Gas Grill

Use and Care Directions Chapter 3

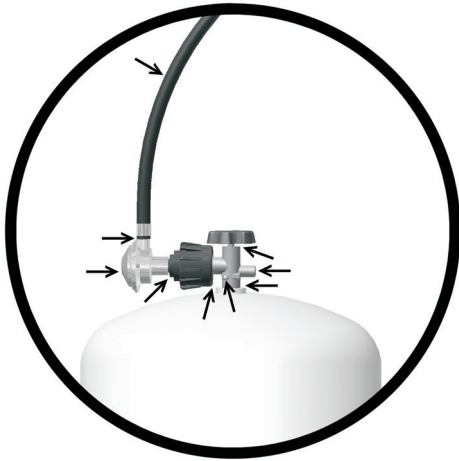

**Leak Testing the
Fuel Supply System**



Lighting Instructions

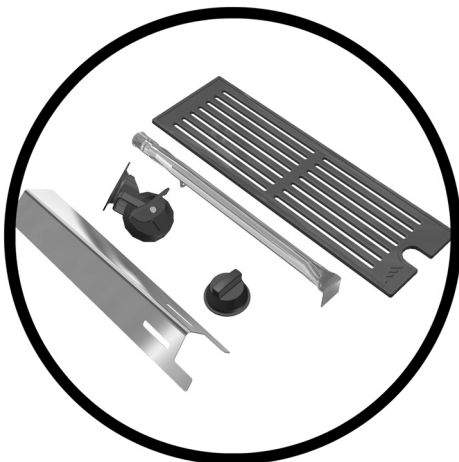

Replacement Parts

Leak Testing

DANGER

To prevent fire or explosion hazard:

- Do not smoke while performing a leak test.
- Do not permit any sources of ignition in the area when testing for leaks.
- Perform leak tests outdoors only.
- Never perform a leak test near a fire or flame.

How to Check the Fuel Supply System for Gas Leaks

1. Mix a solution of equal parts mild detergent or liquid soap and water.
2. Turn off the burner control knobs.
3. Turn the top knob of the fuel-supply cylinder counterclockwise one rotation to open.
4. Apply the soap solution to all connections of fuel-supply assembly.

If no soap bubbles appear, the grill is fine for use.

If bubbles form at the connections, there is a leak. In case of a leak, try tightening the joint. If necessary, replace the faulty part with a replacement part recommended by the manufacturer.

5. Turn off the knob on fuel-supply cylinder.
6. Turn on the burner control knobs for a moment to release pressure in hose, then turn the control knobs back off.
7. Wash off soapy solution with cold water and towel dry.

WARNING: Do not attempt to repair the cylinder valve. If it becomes damaged, the cylinder must be replaced.

If you are unable to stop a leak, shut off the gas supply at the cylinder valve. Remove the cylinder from the grill. Call a gas appliance serviceman or L.P. gas dealer. Do not use appliance until the leak is fixed.

Perform a leak test each time the gas supply cylinder is connected to the regulator. Leak test any time a part of the gas system is replaced. Perform a leak test at least once each year whether the L.P. gas supply cylinder has been disconnected or not.

Have a dealer check the cylinder for deterioration after 10 years, according to DOT regulations. Immediately replace cylinder if any is found.

IMPORTANT! Inspect the gas supply hose regularly. If there are cuts, excessive abrasion or wear, replace the hose prior to operating the appliance.

Use only the hose replacement specified in the parts list for your grill.

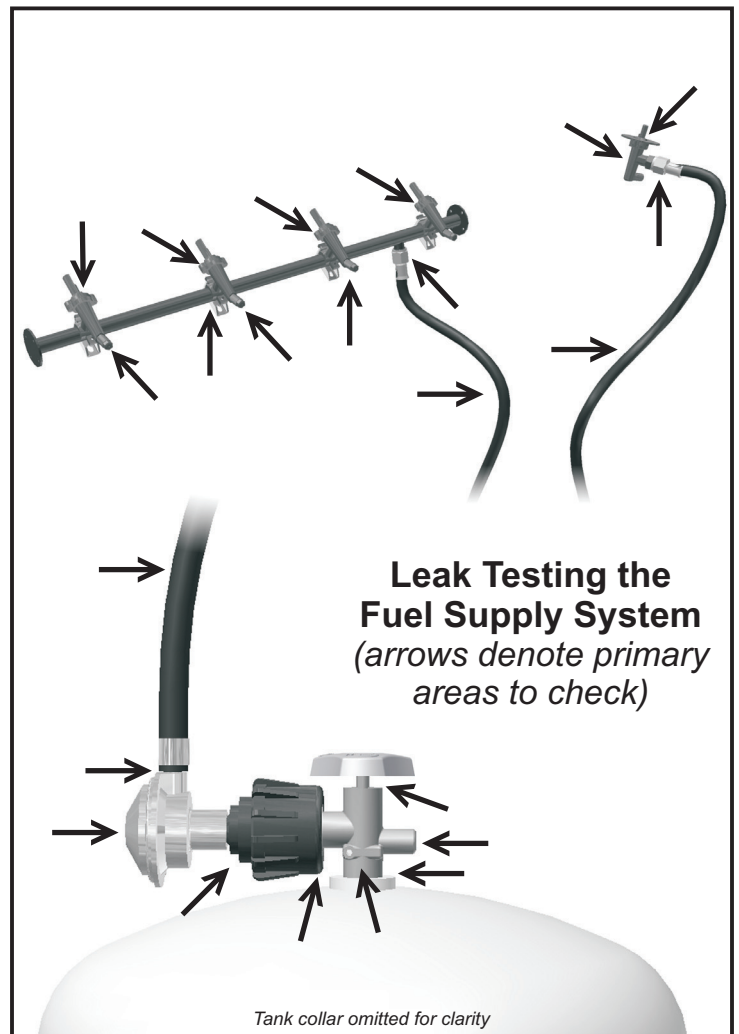

Lighting Instructions

IGNITER LIGHTING SYSTEM

The Igniter System consists of an electronic igniter unit, individual burner-mounted ceramic electrodes, and lead wires. Gas is routed to the electrodes at each burner. When the igniter knob is pressed, an electric spark is created at the ceramic electrode. The gas is then ignited by the spark.

To test: Watch the electrode tip inside the gas collector while activating the igniter. To avoid a possible shock, do not touch the burner or metal parts on igniter system while performing igniter test. A visible spark should jump from the electrode. The spark gap is set when the electrode is installed.

If there isn't a spark, check the lead wires and connections. The igniter wires should be kept away from the grill bottom. Also check that the ceramic electrode that is mounted underneath the burner is not broken.

Sometimes dirt and rust at and around the electrode can prevent an igniter spark. Clean them with a degreaser or warm soapy water, and dry. Remove rust from electrode tip and metal surfaces by lightly sanding with an emery cloth or fine-grain sandpaper.

LIGHTING INSTRUCTIONS

(Read all the steps before beginning.)

STEP 1. Check the burner venturi tubes for blockage from an insect nest (see, "CLEANING THE BURNER VENTURI TUBES").

STEP 2. Ensure that all of the burner-control knobs are in the OFF position.

STEP 3. **OPEN GRILL LID**

WARNING: Attempting to light the grill with the lid down could cause an explosion.

STEP 4. Turn on the fuel supply valve on the L.P. gas cylinder. 1 to 1-1/2 counter-clockwise turn is enough to open the valve.

CAUTION: Do not stand with head or arms over the grill.

STEP 5. To light using the igniter: Push in and turn the left-most burner-control knob counter-clockwise to the high setting.

STEP 6. Immediately press in the igniter button until you hear it clicking. Repeat 4 to 5 times if necessary.

The burner should light.

STEP 7. If the burner fails to light properly, turn the burner control knob off. Also turn off the L.P. cylinder knob. Wait five minutes before attempting to light the burner again. This will allow time for released gas to disperse.

HINT: If the burner does not light after trying again, turn off burner-control knob, the L.P. cylinder knob and try match lighting the grill once the gas has cleared.

If your electronic igniter does not click, you may need to replace the battery. Simply unscrew the igniter button from the control panel to access the battery.

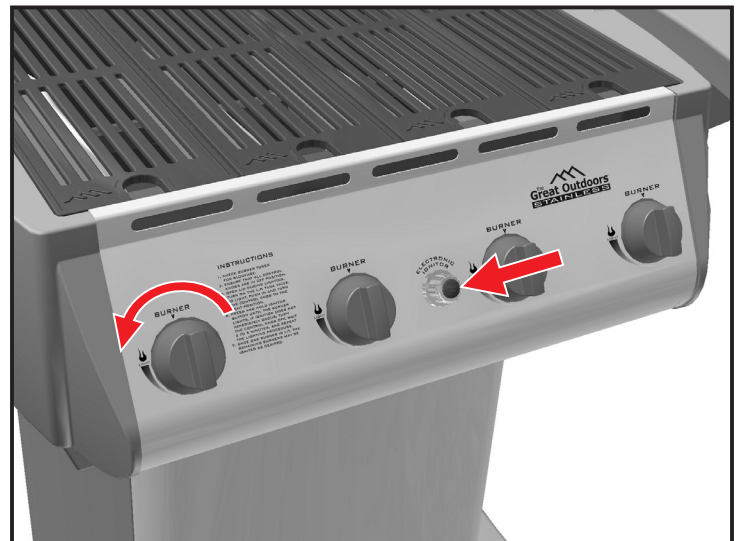

Operating the Control Knobs

Use the **LEFT-MOST** burner gas control knob, **PUSH IN** and rotate counter-clockwise. **PRESS THE IGNITER BUTTON** - you will hear it clicking.

Lighting Instructions

MATCH LIGHTING

IMPORTANT: The match lighting holes are found under the side tables, in the side of the grill tub. When match lighting the grill, use the END gas control knob on the side you are using (closest to the match lighting hole).

Repeat steps 1 to 4 of “Igniter Lighting Instructions.”

STEP 5. To match light: push down and turn the burner control knob counterclockwise to the high setting.

STEP 6. IMMEDIATELY strike a long wooden match and position the burning match through match lighting hole in the grill tub. Extend the flame near a burner port in the burner. The burner should light.

If a long-reach match or lighter is not accessible, there is a match extension provided, attached underneath the side burner table. Insert a match in the holder end of the extension, strike the match, and insert it through the match-lighting hole.

To light other burners, sequentially light one adjacent burner at a time. DO NOT attempt to light a burner that is not directly next to a lit burner without using the igniter.



Locating the Match Lighting Hole

The match lighting holes are located beneath the side tables in the sides of the grill tub.

Allow the grill to preheat with the grill lid closed for five to ten minutes before cooking.

CAUTION: Do not touch any hot grill parts. The outside of the grill bottom becomes very hot during use. It may be necessary to use protective gloves.

HOW TO SHUT OFF THE GRILL

STEP 1. Turn the burner-control knob(s) off. The burner flame will go out.

STEP 2. Turn off the top L.P. cylinder valve by turning the knob in a clockwise direction until it stops.

IMPORTANT: Always have the gas shut off at the L.P. cylinder valve when the grill is not in use. The L.P. cylinder has a leak detection feature which will restrict the amount of gas flow to the burner if the tank shut-off valve has not been turned off prior to the next use.

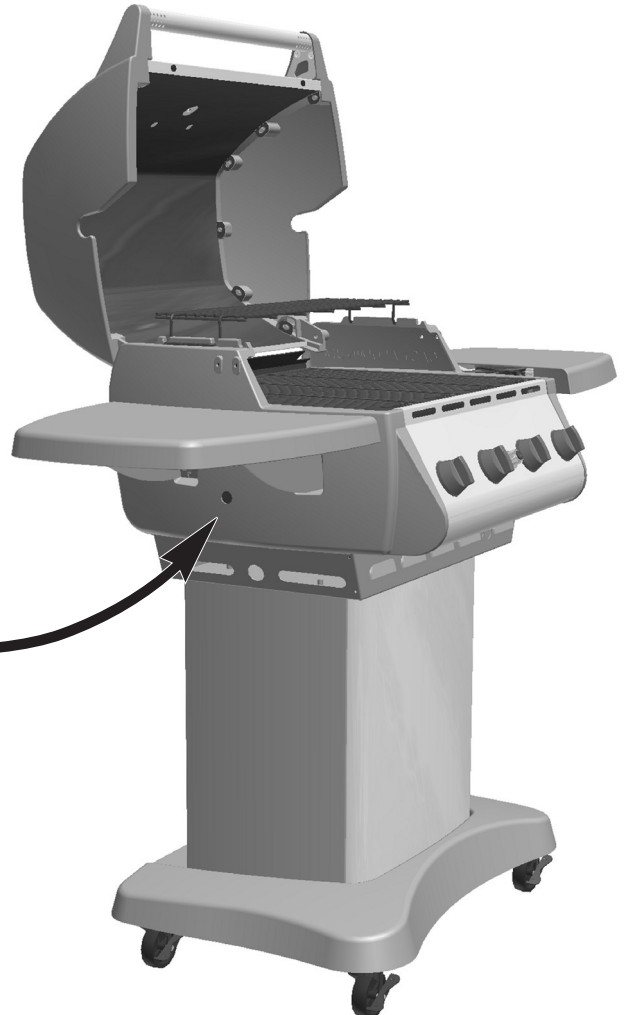

Side Burner Operation

To open the side burner, simply lift up and out on the side burner lid. The lid can be used as additional side table space.

DO NOT place more than 10 pounds of weight on the side burner lid.

DO NOT close the side burner lid while the side burner is on.

The side burner table and lid may be very hot during and after use. Use caution when handling the components.

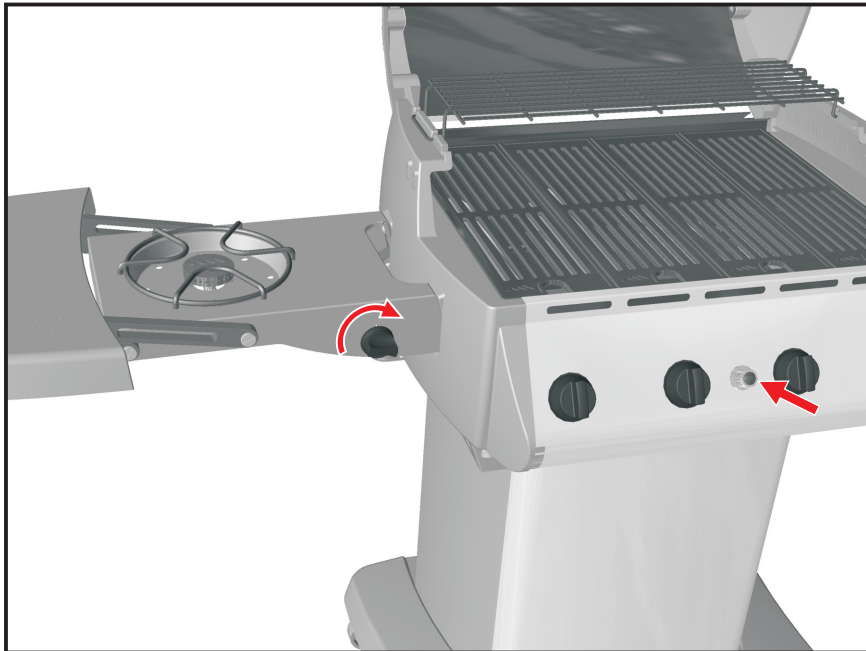
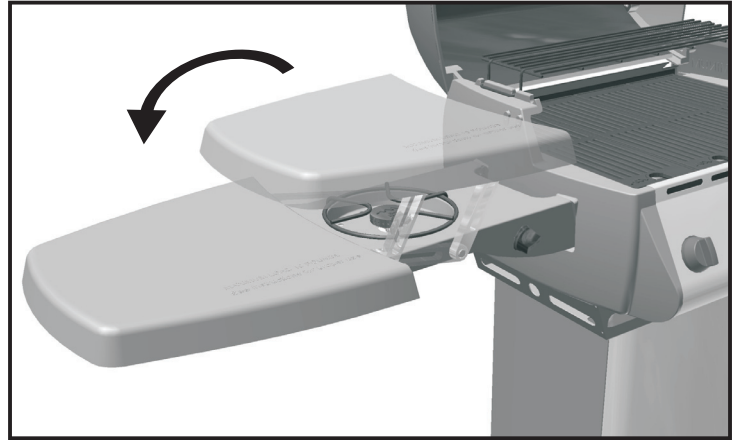

LIGHTING INSTRUCTIONS

1. Open the side burner lid before operating.
2. Open the L.P. Gas Cylinder valve 1 to 1-1/2 turns.
3. Push in and turn the side burner control knob clockwise to the high position.
4. IMMEDIATELY press the electronic igniter on the front control panel of the grill.

The side burner should light - release the electronic igniter.

To match light the side burner, follow steps 1 and 2 above, then strike a match and set it in the side burner, near the burner as shown to the right.

Turn the side burner control knob to the high position. The side burner should light.

To turn off the side burner, turn the side burner control knob counter-clockwise to the Off position.

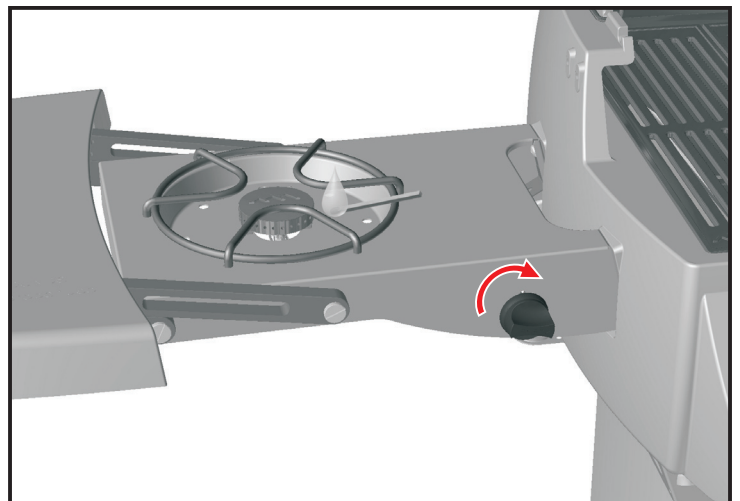

Using Your Gas Grill

TO BREAK IN A NEW GRILL

Before using it for the first time; operate the grill with lid closed on a low setting for about 30 to 45 minutes to “season” the grill. This will help burn away oil and the smell of new paint. After the oil has burned away, check the burner flame.

BURNER'S FLAME

Keep the grill lid closed and the grids in place. Inspect the burner's flame by carefully looking below and through the air-supply openings in the grill bottom.

A good flame should be blue with some yellow tip coming from the burner holes. Some yellow tips on flames up to 1" in length are acceptable as long as no carbon or soot deposits appear.

If flames are excessively yellow and irregular, the oil residue may not be completely burned off, or the venturi may not be properly positioned over the orifice(s). Allow grill to cool before repositioning venturi over valve.

After a grill has been in use for a while it may begin to have a more yellow flame. A build up of food deposits, fats, or cooking seasonings can cause yellowing of flames. Try cleaning the burner to remove built-up residue. Check for clogged burner holes or blocked venturi tubes.

Regular use of your grill will actually help keep it operating more smoothly. It is not unusual for similar units to heat a little differently.

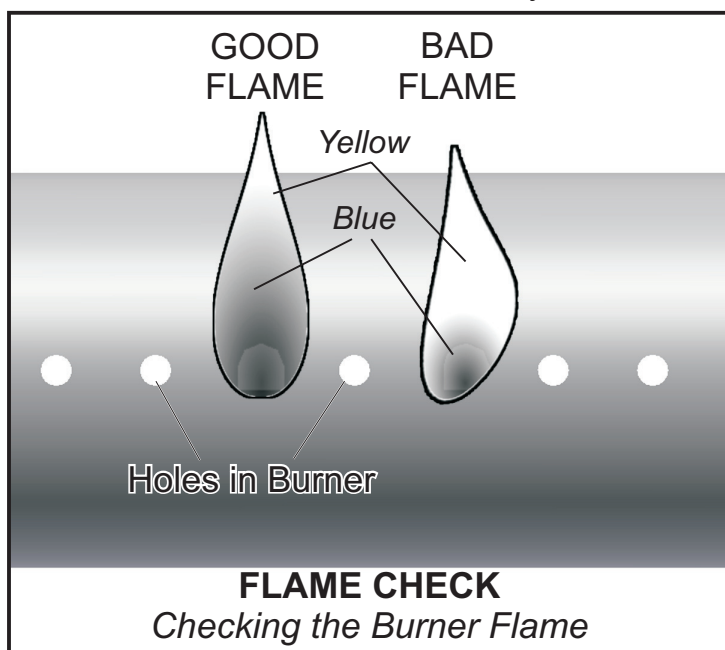

CONTROL SETTINGS

The high flame setting is for quick searing of meat. Sear foods, then finish cooking on a lower setting.

A medium setting works best for cooking steaks, pork chops, and hamburgers.

The lowest setting works well for all roasts and rotisserie foods. Even thick steaks, when seared on a high setting first, will have a better texture and be more juicy cooked on low.

MULTIPLE BURNER COOKING SYSTEM

The grill's burners may be operated to cook on either side or both sides at once. This allows for various styles of cooking.

1. Use a direct heat source when browning meat or cooking hot dogs and hamburgers. Check the food often.

2. Cook large-size foods (such as roasts, turkey, or duck) on a low, direct heat. Place food and water in foil pan with corrugated bottom, adding water as needed.

CAUTION: Never use a glass dish of any kind to either warm up or cook food on a grill. Personal injury or damage may occur.

3. If doing skillet or stir-fry cooking, limit the amount of oil and direct heat used.

4. Cook foods that burn easily over an indirect heat. Light a burner on one side and place the food on the other side for cooking. The food will cook slower but should be more tender. This method of cooking also reduces grease flare-up. Add a small pan of water to help keep meat moist, replace the water as needed.

5. Casseroles can be cooked in oven-proof or foil pans using indirect heat.

6. Cook two foods at once using different settings.

7. To add smoked flavor, try adding wood chips in apple, mesquite, and hickory flavors.

Caring for Your Gas Grill

COOKING TIPS

Prior to lighting the grill, coat the cooking grids with cooking oil to prevent food from sticking. Preheat the grill with the lid closed about five to ten minutes before cooking. Cook with lid down when possible. This will keep temperature even, conserve fuel, improve food's flavor, and lessen flare-ups.

Never leave cooking food unattended. Frozen meat and poultry should be thawed before cooking. Trim the excess fat. Frozen fish and vegetables will cook without thawing. However, placing frozen food onto very hot porcelain grids can crack the porcelain finish.

Add salt to food after cooking to prevent it from drying out. Brush naturally lean meat, poultry or fish with cooking oil or margarine.

Cook small pieces of tender foods in foil. Apply barbecue, tomato, or sugar-based sauces no sooner than the last ten minutes of cooking. Turn food with a long-handled spatula or tongs.

During operation, stand to side of grill when opening the grill lid. Lift lid handle slowly in case of a grease flare-up. Do not position any part of your body directly above the cooking area. Some flare-up is expected. It adds a smoky flavor and sears food, but a major grease fire can cause a potentially hazardous situation and damage the grill.

IN CASE OF A MAJOR GREASE FIRE, follow these steps:

1. Turn the burner-control knob(s) to off.
2. Stay away from grill.
3. Allow the fire to burn itself out.
4. After the fire is out and the grill is cool, shut off the fuel supply valve at the fuel source.
5. Clean all parts.
6. Check for damage to the gas-supply hose, burner valve, and burner. On L.P. appliances also check the L.P. cylinder, L.P. cylinder valve, regulator and hose. If any of these parts are damaged, replace them with factory authorized parts before operating the appliance again.

CARING FOR YOUR GRILL

Regular care of your grill will help keep it operating properly. Cleaning or maintenance may be done only when the grill is cool and with the fuel supply turned off. Clean grill parts and tighten loose hardware as needed.

Do not put grill parts in a self-cleaning oven as the extreme heat could damage them. Do not use a combustible or flammable cleanser on grill. Do not use a commercial oven cleaner.

Always keep the grease pan beneath the grill bottom to catch grease drippings during use. **CAUTION:** The grease pan and grill bottom become extremely hot during use. To avoid burns empty grease pan only when the grill is cool.

The small vent hole in the regulator must be kept clean of dirt and debris. Keep the gas-supply hose at least 3" away from any grill surface that becomes hot during use.

REGULAR CLEANING AND UPKEEP

After each cooking, shut the lid and turn control knobs to highest setting for 5 minutes to burn off grease drippings inside grill.

Use a brass bristle brush on the porcelain coated cooking grids. Wash the cooking grids with a mild soap, a scrub brush and hot water. Use a mild soap and hot water to wash all other grill parts.

To refinish the outside of the cast aluminum grill end caps, clean and then lightly sand with a fine sandpaper. Clean with a vinegar / water solution, and rinse with water. When dry, paint with a high temperature paint following directions on paint can label.

IMPORTANT: NEVER leave a grill unattended when in use.

Cleaning and Maintenance

Inspect and clean the burners regularly. Remove grill components from the grill bottom necessary to get to the burner inside. Use a wire bristle brush to clean the burner surface. A straightened paper clip is useful to remove debris or rust from the small burner ports.

CLEARING THE BURNER TUBES

Spiders and other insects are known to sometimes build homes inside the burner tubes. This can become a serious problem. A spider web or wasp nest inside the burner tube can block gas flow and can cause a fire at the gas control valve. Such a fire can cause operator injury and do serious damage to your grill. The burner tubes have fine screens to discourage spiders and insects from building a nest inside. However, some very small spiders may spin webs inside the tubes.

Inspect the burner tubes if a blockage is suspected.

First, disconnect and remove the fuel source from the grill.

Next detach and remove the burner from grill bottom by lifting from the back, rotating and sliding out the front of the tube. Make sure to disconnect the igniter wire.

Insert a long pipe cleaner (about 20" long) inside the burner tubes to loosen and remove blockages. Use care so as not to damage the screens inside the tubes. A high pressured stream of water may also be used.

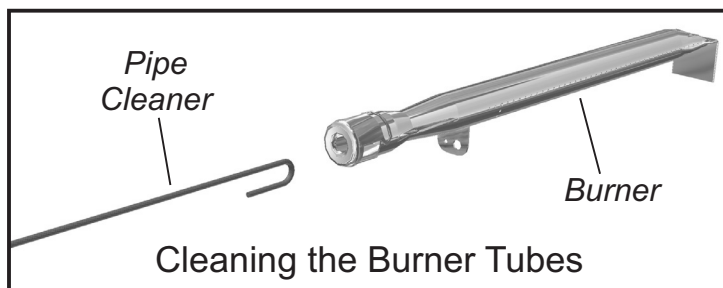

If a blockage occurs inside the gas-control valve, located behind the control panel, it may be necessary to clear the valve orifices. Unscrew the orifices from rear of the gas-control valve. Wash the orifices and blow air through the small end holes. Replace the orifices into the valve ends when they are dry.

WARNING: Never attempt to operate your grill without orifices in the valve. A serious and immediate fire hazard would result.

Replace the burners into the grill bottom after they are clean.

IMPORTANT! Make sure the valve orifices are inside burner tubes. Secure burner to the grill bottom, and reconnect the igniter wires. Replace all other parts inside grill. Reconnect the fuel cylinder to grill. Inspect the condition and position of the gas-supply hose.

STORING AN L.P. GRILL

WARNING: Store an L.P. gas-supply cylinder outdoors in a cool area, out of direct sunlight, and away from people or pets.

Portable grills can be stored indoors without the cylinder. If leaving it outdoors, cover the grill for protection from weather.

OPTIONAL ELECTRICAL ACCESSORIES

If owner-supplied electrical accessories are used with grill (such as an electric rotisserie), follow specification statements included with the accessory. Do not allow cord to touch any hot surfaces that could melt the insulation.

IMPORTANT: If using an external electrical source, the installed appliance must be electrically grounded according to local codes or, in the absence of local codes, with the National Electrical Code, ANSI/NFPA 70 or the Canadian Electrical Code CSA C22.1.

Grounding Instructions: Use an appliance equipped with a three-prong grounding plug for your protection against shock hazard. It should be plugged directly into a properly grounded three-prong receptacle. Do not remove the grounding prong from a three-prong plug.

Long detachable power-supply cords or extension cords can also be used with care. The marked electrical rating of the cord set or extension cord should be at least as great as the electrical rating of the appliance. If the appliance is of the grounded type, the extension cord should be a grounding-type 3 wire cord. Use outdoor extension cords with a surface marked with suffix letters "W-A" and with a tag stating "Suitable for Use with Outdoor Appliances."

Keep the connection to an extension cord away from water and off the ground. Arrange the cord so that it will not drape over the counter top or tabletop where it can be pulled or tripped over.

Do not clean any electrical product with a water spray or the like. Store electrical products indoors out of reach of children when not in use.

Stainless Series Replacement Parts

Replacement parts are available direct from our warehouse. Some components are not available preassembled and may be ordered separately. For convenience, the following parts list is provided along with a representation of the items listed. Charges for replacement parts and shipping may apply.

For warranty replacements, proof of ownership and date of purchase is required. Please call 888-869-5454 to receive a return authorization number before returning any grill components. To order parts call toll free: 888-869-5454 (M-F, 8:00am-4:30pm) or write to: **The Great Outdoors Grill Company**

**7980 East American Drive
Joplin, Missouri U.S.A. 64804**

Item No.	Part No.	Part Description
1	AZ001200	Grill Lid Assembly
2	AZ001201	Heat Indicator
3	AZ001202	Cooking Grid (4)
4	AZ001203	Heat Tent (4)
5	AZ001204	Burner Tube (4) w/ electrode
6	AZ001205	Warming Rack
7	AZ001206	Side Burner Table Ass'y (all)
8	AZ001207	Side Burner Grate
9	AZ001208	Side Burner Knob
10	AZ001209	Side Burner Igniter Electrode
11	AZ001210	Cast Brass Burner
12	AZ001211	Side Burner Valve
13	AZ001212	Grill Tub Assembly
14	AZ001213	Side Table
15	AZ001214	Control Panel
16	AZ001215	Burner Valve Assembly
17	AZ001216	Igniter Button
18	AZ001217	Control Knob (4)
19	AZ001218	Grease Pan
20	AZ001219	Pillar Side Panel (2)
21	AZ001220	Collar Assembly w/ Ignitor Module
22	AZ001221	Pillar Front Panel
23	AZ001222	L.P. Gas Hose w/ Regulator
24	AZ001223	Tank Retainer Wire
25	AZ001224	Caster
26	AZ001225	Cylinder Support
27	AZ001226	Grill Base Assembly

Not Shown:

- AZ001227 Master Hardware Pack
- AZ000803 "AA" Battery

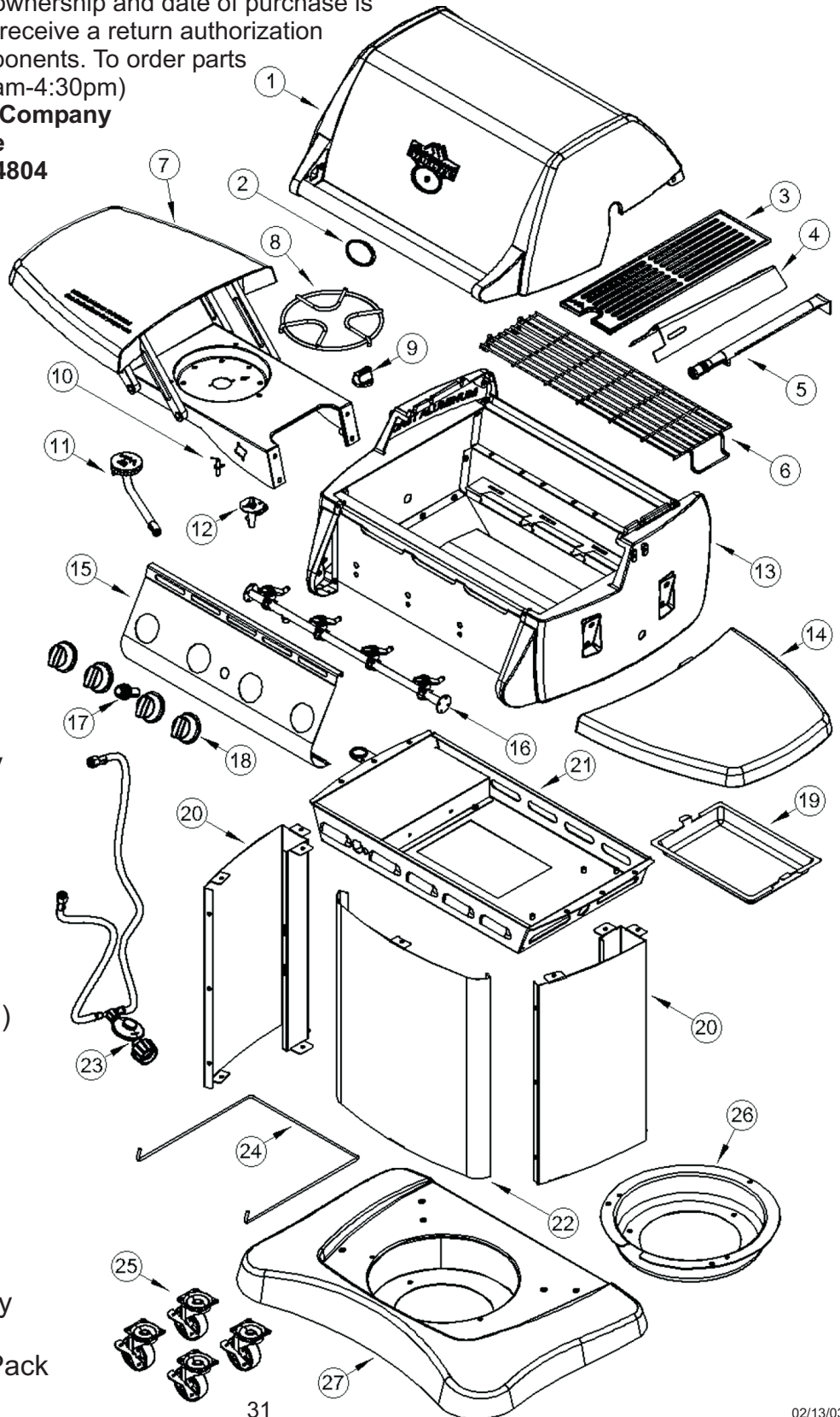

Outdoor Cooking

Recipes Chapter 4

BEEF

FLAVORFUL FLANK STEAK

1 beef flank steak (about 2 pounds)
3 tablespoons ketchup
1 tablespoon vegetable oil
1 tablespoon chopped onion
1 teaspoon brown sugar
1 teaspoon Worcestershire sauce
1 garlic clove, minced
1/8 teaspoon pepper

Place flank steak in an 11-in. x 7-in. x 2-in. glass dish. Combine remaining ingredients; pour over meat.

Cover and refrigerate for at least 4 hours. Remove meat, discarding marinade.

Grill over hot grill until meat reaches desired doneness, about 4 minutes per side for medium, 5 minutes per side for medium-well.

Slice into thin strips across the grain to serve.
Yield: 8 servings.

BETTER BURGERS

1 pound ground beef or turkey
4 teaspoons prepared horseradish
2 teaspoons Dijon mustard
1 teaspoon paprika
1/4 teaspoon pepper
1/8 teaspoon salt, optional
4 hamburger buns, split

In a bowl, combine the first six ingredients; mix well. Shape into four patties. Grill until desired doneness. Serve on buns.

Yield: 4 servings

DISAPPEARING SHISH KEBOBS

1/2 cup ketchup
1/2 cup sugar
1/2 cup soy sauce
1 teaspoon garlic powder
1 teaspoon ground ginger
2 pounds boneless beef sirloin steak (1-1/2 inches thick), cut into 1-1/2-inch cubes
1/2 fresh pineapple, trimmed and cut into 1-inch chunks
2 to 3 small zucchini, cut into 1-inch chunks
1/2 pound whole fresh mushrooms (medium size work best)
1/2 pound boiling onions, peeled
1 large green or sweet red pepper, cut into 1-inch pieces

Combine first five ingredients; toss with beef. Cover and refrigerate overnight. Drain beef, reserving marinade. Thread meat, pineapple and vegetables alternately on long skewers.

Cook on a hot grill 15-20 minutes, turning often, or until meat reaches desired doneness and vegetables are tender.

Simmer the marinade in a small saucepan over low heat for 15 minutes. Remove meat and vegetables from skewers; serve with marinade.
Yield: 6-8 servings.

HINT: Soak wooden or bamboo skewers in water about a half hour prior to cooking.

POULTRY

GRILLED CHICKEN

1 broiler/fryer chicken
(3-1/2 to 4 pounds), quartered
1/4 cup vinegar
1/4 cup butter or margarine
1/4 cup water
1/4 teaspoon dried thyme
1/4 teaspoon oregano
1/4 teaspoon rosemary
1/4 teaspoon garlic powder
1/8 teaspoon salt
1/8 teaspoon pepper

Place chicken in a shallow glass dish. In a small saucepan, combine all remaining ingredients; bring to a gentle boil. Remove from the heat. Pour over chicken. Cover and refrigerate for 4 hours, turning once. Drain and discard marinade. Grill chicken, covered, over medium heat for 30-40 minutes or until juices run clear. **Yield:** 4 servings.

TASTY TURKEY

1/4 cup soy sauce
1/4 cup vegetable oil
1/4 cup apple juice
2 tablespoons lemon juice
2 tablespoons dried minced onion
1 teaspoon vanilla extract
1/4 teaspoon ground ginger
Dash of garlic powder
Dash of pepper
2 turkey breast tenderloins
(about 1/2 pound each)

In a large resealable plastic bag or shallow glass dish, combine the soy sauce, oil, apple juice, lemon juice, onion, vanilla, garlic powder and pepper. Add turkey; seal or cover and refrigerate for at least 2 hours. Discard marinade. Grill turkey, covered, over medium heat for 8-10 minutes per side or until juices run clear. **Yield:** 4 servings.

PORK

BEST PORK RIBS

3 pounds country-style pork ribs
1/2 teaspoon garlic salt
1/2 teaspoon pepper
1 cup ketchup
1/2 cup packed brown sugar
1/2 cup honey
1/4 cup spicy brown mustard
2 tablespoons Worcestershire sauce
1-1/2 teaspoons liquid smoke, optional

Place ribs in a large kettle or Dutch oven; sprinkle with garlic salt and pepper. Add enough water to cover. Cook on your kitchen stove and bring to a boil. Reduce heat; cover and simmer for 1 hour or until juices run clear and ribs are tender; drain. Meanwhile, combine the remaining ingredients. Remove ribs from kettle to barbecue the ribs. Grill ribs, uncovered, over medium heat for 10-12 minutes, basting with sauce and turning occasionally. **Yield:** 4 servings.

HMM - HMM HAM STEAK

1-pound ham steak, 1/2 inch thick
1 tablespoon Dijon mustard
1 tablespoon honey
1 tablespoon apricot preserves

Cut outer edge of fat on ham diagonally at 1-inch intervals to prevent curling (do not cut into ham). Mix mustard, honey and preserves. Grill ham uncovered 4 to 6 inches from medium-high heat 4 minutes. Turn ham; brush with mustard mixture. Grill 4 minutes longer. Turn ham; brush with remaining mustard mixture. Grill about 2 minutes longer or until heated through. **Yield:** 4 servings.

GRILLED HAM & SWISS SANDWICHES

1/4 cup butter, softened
2 tablespoons horseradish mustard
2 tablespoons chopped onion
2 tablespoons poppy seed
6 ounces thinly sliced ham
6 ounces sliced Swiss cheese
6 sandwich buns

Mix butter, mustard, onion and poppy seed. Spread mixture on both halves of each bun; layer a slice of Swiss cheese and several ham slices between halves. Wrap each sandwich in foil and grill for 20 minutes. Serve warm. **Yield:** 6 servings.

FISH / SEAFOOD

SHRIMP COMBO PACKETS

4 cups peeled potatoes (about 1-1/4 lbs.), sliced 1/8-inch thick
1 cup sliced leeks or mild onions
1 cup chopped plum tomatoes
20 jumbo shrimp (about 1 lb.)
peeled and deveined
4 Tablespoon butter
2 teaspoon dill weed, crushed
1 teaspoon garlic powder
1 teaspoon salt
1/2 teaspoon ground black pepper

On work surface, place 4 sheets of heavy-duty or doubled aluminum foil each about 20 inches long. In the center of each, arrange 1/2 cup potatoes, overlapping slightly; top with 1/4 cup each leeks and tomatoes and 5 shrimp.

Dot with 1 tablespoon butter; sprinkle with 1/2 teaspoon dill weed, 1/4 teaspoon garlic powder, 1/4 teaspoon salt and 1/8 teaspoon black pepper. Arrange remaining potatoes over shrimp, overlapping slightly.

Bring long sides of foil together over mixture, allowing space for heat circulation and expansion; fold down to seal. Fold up short ends; crimp to seal. Place on grill. Cook until potatoes are tender and shrimp are cooked, approximately 20 minutes on the grill. Carefully lift pouch from grill and place in serving dish. Open carefully, allowing steam to escape. **Yield:** 4 servings.

SUPER SALMON

1-1/2 cups packed brown sugar
6 tablespoons butter or margarine, melted
3 to 6 tablespoons lemon juice
2-1/4 teaspoons dill weed
3/4 teaspoon cayenne pepper
1 salmon fillet (about 2 pounds)
Lemon-pepper seasoning

In a small bowl, combine the first five ingredients; mix well. Remove 1/2 cup to a saucepan; simmer until heated through. Set aside remaining mixture for basting. Sprinkle salmon with lemon-pepper. Place on grill with skin side down. Grill, covered, over medium heat for 5 minutes. Brush with the reserved brown sugar mixture. Grill 10-15 minutes longer, basting occasionally. Serve with the warmed sauce. **Yield:** 6-8 servings.

SIDE DISHES

RICE ON THE SIDE

1-1/3 cups uncooked instant rice
1/3 cup sliced fresh mushrooms
1/4 cup chopped green pepper
1/4 cup chopped onion
1/2 cup chicken broth
1/2 cup water
1/3 cup ketchup
1 tablespoon butter or margarine

In a 9-in. round aluminum foil pie pan, combine the first seven ingredients. Dot with butter. Cover with heavy-duty foil; seal edges tightly. Grill, covered, for 14 to 15 minutes or until liquid is absorbed. Fluff with a fork and serve immediately. **Yield:** 6 servings

AU GRATIN POTATO POUCHES

4 cups frozen O'Brien potatoes (16 ounces)
1 tablespoon vegetable oil
1/2 teaspoon seasoned salt
3/4 cup shredded Cheddar cheese (3 ounces)

Spray 18x13-inch foil with piece of heavy-duty aluminum foil with cooking spray. Place potatoes on foil. Drizzle with oil; sprinkle with seasoned salt. Wrap foil securely around potatoes. Grill on medium heat 30 minutes, turning once. Carefully open packet; sprinkle cheese over potatoes. Cover loosely and let stand for 4 to 5 minutes or until cheese is melted. **Yield:** 6 servings.

GRILLED BREADS

1 One pound loaf frozen bread dough,
white or honey wheat, thawed

2 tablespoons olive oil

Suggested Toppings for bread:

Sliced fresh tomatoes with basil and grated Fontina cheese, OR Grilled onions, OR Fresh herbs and garlic, OR Grated Parmesan cheese and garlic, OR pizza sauce with grated mozzarella cheese and sliced olives, OR feta cheese and black olives

Divide dough into 4 equal pieces. Flatten each into a 6-inch round. Brush one side of each round with oil. Place oiled-side down on an oiled grid at medium heat. Cover and cook until browned and firm, about 5 minutes. Brush tops with oil; turn breads over. Top cooked side of bread with a suggested topping. **Yield:** 4 servings.

VEGETABLES

ONION BLOOM

1 Bermuda onion
1 tablespoon butter
2 teaspoons honey
1/2 teaspoon Worcestershire sauce

Peel onion; cut 1/2 -inch slice from top of onion and leave root end. Cut onion from top into 8 wedges to within 1/2-inch of root end. Gently pull wedges apart. Brush 12-inch square of heavy-duty aluminum foil with vegetable oil. Place onion on square; loosely shape foil around onion. Sprinkle onion with butter, honey and Worcestershire sauce. Wrap foil securely around onion. Cover and grill onion at medium heat 50 - 60 minutes or until very tender.

Yield: 1 serving.

VEGETABLES ON A STICK

2 medium zucchini, cut into 1-inch slices
2 medium yellow summer squash, cut into 1-inch slices
1/2 pound whole fresh mushrooms
1/3 cup olive or vegetable oil
2 tablespoons lemon juice
1-1/2 teaspoons dried basil
1-1/2 teaspoons dried parsley flakes
3/4 teaspoon garlic powder
3/4 teaspoon dried oregano
1/2 teaspoon salt
1/8 teaspoon pepper

On skewers, alternately thread zucchini, yellow squash and mushrooms. In a bowl, combine the remaining ingredients. Brush some of the mixture over vegetables. Grill, uncovered, over medium heat for 10-15 minutes or until vegetables are tender, turning and basting occasionally with herb mixture.

Yield: 4 servings.

HOW TO GRILL FROZEN VEGETABLES

Tear off a 36x18-inch piece of heavy duty foil. Fold in half to make an 18-inch square. Fold up sides, using your fist to form a pouch. Place one 10-ounce package frozen vegetables in center of pouch. Season with salt and pepper; top with a pat of butter or margarine. Fold edges of foil to seal pouch securely, leaving space for expansion of steam. Grill over medium-hot until vegetables are cooked. Allow about 20 minutes for peas and other small vegetables; allow more time for larger vegetables. Turn the package of vegetables frequently.

DESSERTS

CINNAMON APPLES

4 medium tart apples, cored
4 teaspoons brown sugar
1/4 cup red-hot candies
Vanilla ice cream, optional

Place each apple in the center of a piece of heavy duty foil (12 in. square). Spoon 1 teaspoon sugar and 1 tablespoon red-hots into the center of each apple. Fold foil around apple and seal tightly. Grill, covered, over medium-hot heat for 30 minutes or until apples are tender. Carefully transfer apples and syrup to bowls. Serve warm with ice cream if desired.

Yield: 4 servings.

SUMMER MEDLEY

3 medium ripe peaches, halved and pitted
1 cup fresh blueberries
2 tablespoons brown sugar
2 tablespoons butter or margarine
1 tablespoon lemon juice

Place each peach half, cut side up, on a double thickness of heavy duty foil (12 in. square). Sprinkle each with about 2 tablespoons blueberries, 1 teaspoon of brown sugar, 1 teaspoon butter and 1/2 teaspoon lemon juice. Fold foil around the peaches and seal tightly. Grill, covered, over medium-low heat for 18-20 minutes or until the peaches are tender.

Yield: 3 servings.

MEXICAN SMORES

1/2 cup creamy peanut butter
4 flour tortillas (8 inches)
1 cup miniature marshmallows
1/2 cup miniature semisweet chocolate chips
Vanilla ice cream

Spread 2 tablespoons of peanut butter on each tortilla. Sprinkle 1/4 cup marshmallows and 2 tablespoons chocolate chips on half of each tortilla. Roll up, beginning with the topping side. Wrap each tortilla in heavy-duty foil; seal tightly. Grill, covered, over low heat for 5-10 minutes or until heated through. Unwrap tortillas and place on dessert plates. Serve with ice cream.

Yield: 4 servings.



Manufacturer's Limited Warranty



The Great Outdoors grill is guaranteed against broken or damaged parts at the time of purchase. Components are guaranteed against defect as follows: All cast-aluminum and stainless steel panel parts are warranted against burn through and structural failure excluding paint, neglect, or abuse, for 75 years from the date of purchase. The stainless steel burners and the cast brass side burner have a limited pro-rated warranty of 10 years from date of purchase. If the burner should fail to operate during the warranty period, the Great Outdoors Grill Company will prorate the cost of a replacement burner. (Pro-rated consumer cost for burner replacement: up to 2 years - free replacement; 2 to 4 years - 20% of replacement cost; 4 to 6 years - 40% of replacement cost; 6 to 8 years - 60% of replacement cost; 8 to 10 years - 80% of replacement cost) All other parts carry a 5-year limited warranty, except paint, which is guaranteed to be free of defects for 90 days.

This warranty is void if the grill collar, heat shield and/or heat gaskets are removed from the grill. This warranty does not cover damage or issues related to neglect, abuse, or modifications to the product or for grills used commercially. This warranty does not cover batteries used in the electronic ignition, battery failure or damage caused by battery malfunction. This warranty covers parts only and does not cover repair labor costs.

All parts that meet the warranty requirement will be shipped at no-charge via the discretion of the Customer Service Department (ground shipments, US Mail, or Parcel Post ONLY). Any Special handling charges (i.e. Second Day, Overnight, etc.) will be the responsibility of the consumer.

All warranty claims apply only to the original purchaser and require a proof of purchase verifying purchase date. Do not return parts to our address without first obtaining a return authorization number from our customer service. This service is available by calling toll free 888-869-5454. (M-F, 8:00am - 4:30pm)



This warranty may give you specific legal rights that vary by state.



7980 East American Drive
Joplin, Missouri USA 64804

- A CFM Company -

www.gogrills.com